

CORPORATE HEADQUARTERS

5100 North River Road
Schiller Park, Illinois 60176 • U.S.A.
847.288.3300 • FAX: 847.288.3702
800.735.3867 (Toll-free within U.S.A., Canada)

INTERNATIONAL OFFICES

LIFE FITNESS ASIA PACIFIC LTD

Room 2610, Miramar Tower
132 Nathan Road
Tsimshatsui, Kowloon
HONG KONG
Telephone: (+852) 2891.6677
FAX: (+852) 2575.6001

LIFE FITNESS ATLANTIC BV

LIFE FITNESS BENELUX

Bijdorpplein 25-31
2992 LB Barendrecht
THE NETHERLANDS
Telephone: (+31) 180.646.666
FAX: (+31) 180.646.699

LIFE FITNESS BENELUX NV

Parc Industriel de Petit-Rechain
4800 Verviers
BELGIUM
Telephone: (+32) 87.300.942
FAX: (+32) 87.300.943

LIFE FITNESS DO BRAZIL

Av. Dr. Dib Sauaia Neto 1478
Alphaville, Barueri, SP
06465-140
BRAZIL
Telephone (+55) 11.4193.8282
FAX: (+55) 11.4193.8283

LIFE FITNESS AUSTRIA

Vertriebs GmbH
Hintschiggasse 1
1100 Vienna
AUSTRIA
Telephone: (+43) 1.61 57 198
FAX: (+43) 1.61 57 198.20

LIFE FITNESS IBERIA

Pol. Ind. Molí dels Frares. c/C, nº 12
08620 Sant Vicenç dels Horts (Barcelona)
Espanña
Telephone: (+34) 93.672.4660
FAX: (+34) 93.672.4670

LIFE FITNESS EUROPE GMBH

Siemensstrasse 3
85716 Unterschleissheim
GERMANY
Telephone: (+49) 89.31 77 51.0
FAX: (+49) 89.31 77 51.99

LIFE FITNESS ITALIA S.R.L.

Via San Pieretto
37010 AFFI (Verona)
ITALY
Telephone: (+39) 045.7238204
FAX: (+39) 045.7238197

LIFE FITNESS LATIN AMERICA and CARIBBEAN

5100 North River Road
Schiller Park, Illinois 60176
U.S.A.
Telephone: (+1) 847.288.3300
FAX: (+1) 847.288.3762

LIFE FITNESS UK LTD

Queen Adelaide
Ely, Cambs CB7 4UB
UNITED KINGDOM
Telephone: (+44) 1.353.666 017
FAX: (+44) 1.353.666 018

LIFE FITNESS JAPAN

Nippon Brunswick Bldg., #8F
5-27-7 Sendagaya
Shibuya-Ku, Tokyo
Japan 151-0051
Telephone: (+81) 3.3359.4309
FAX: (+81) 3.3359.4307

Before using this product, it is essential to read this ENTIRE operation manual and ALL installation instructions.

It describes equipment setup and instructs members on how to use it correctly and safely.

Avant d'utiliser ce produit, il est indispensable de lire ce manuel d'utilisation dans son INTÉGRALITÉ, ainsi que TOUTES les instructions d'installations.

Ce manuel explique comment installer l'équipement et comment l'utiliser correctement et sans danger.

FCC Warning - Possible Radio / Television Interference

NOTE: *This equipment has been tested and found to comply with the limits for a Class A digital device, pursuant to part 15 of the FCC rules. These limits are designed to provide reasonable protection against harmful interference when the equipment is operated in a commercial environment. This equipment generates, uses and can radiate radio frequency energy, and if not installed and used in accordance with the instruction manual, may cause harmful interference to radio communications. Operation of this equipment in a residential area is likely to cause harmful interference in which case the user will be required to correct the interference at his own expense.*

Class SB (Studio): Professional and / or commercial use.



CAUTION: Any changes or modifications to this equipment could void the product warranty.

Mise en garde : tout changement ou toute modification de ce matériel peut annuler la garantie du produit.

Any service, other than cleaning or user maintenance, must be performed by an authorized service representative. There are no user serviceable parts.

TABLE OF CONTENTS

Section	Description	Page
1.	Getting Started	5
1.1	Important Safety Instructions	5
1.2	Setup	9
	Electrical Power Requirements // Grounding Instructions // Removing and Replacing the Wax Bag // How to Position and Stabilize the Life Fitness® Treadmill // Power Switch // Immobilizing the Treadmill // Centering the Belt // Fitness Networking and Entertainment // Power Cord Routing	
2.	The Display Console	15
2.1	Display Console Overview	15
2.2	Display Console Descriptions	16
2.3	Emergency Stop System	18
2.4	Reading Rack	18
2.5	Accessory Trays	18
3.	Heart Rate Zone Training Exercise	19
3.1	Why Heart Rate Zone Training Exercise?	19
3.2	Heart Rate Monitoring	20
	The Lifepulse™ Digital Heart Rate Monitoring System // The Polar Telemetry Heart Rate Monitoring Chest Strap	
4.	The Workouts	22
4.1	Workout Overviews	22
4.2	Using the Workouts	22
	Logging on to a Network // Setting Up the Workouts without Networking Enabled (91Ti only) // Setting Up a Workout (90T only) // Using Quick Start // Selecting a Level // Using ZerOut® Speed Control // Selecting an Alternate Goal Type // Cool-Down	
4.3	Workout Descriptions	25
	Manual // Hill // Random // Fat Burn // Cardio	
5.	The Manager's Configuration	28
5.1	Entering and Using the Manager's Configuration	28
5.2	Configuration Settings	29
	91Ti Settings // 90T Settings	
6.	Service and Technical Data	31
6.1	Preventive Maintenance Tips	31
6.2	Preventive Maintenance Schedule	32
6.3	Troubleshooting the Lifepulse System Sensors	33
6.4	Troubleshooting the Polar Heart Rate Chest Strap	33
	Heart Rate Reading Is Erratic or Absent Entirely // Heart Rate Reading Is Erratic or Extremely High	
6.5	Removing the Accessory Trays	34
6.6	How to Adjust and Tension the Striding Belt	34
	The Belt Tensioning Bolts // Tracking (Centering) a Striding Belt // Tensioning an Existing Striding Belt	
6.7	How to Obtain Product Service	37
7.	Specifications	38
7.1	Life Fitness 91Ti Treadmill Specifications	38
7.2	Life Fitness 90T Treadmill Specifications	39

© 2006 Life Fitness, a division of Brunswick Corporation. All rights reserved. Life Fitness, Lifecycle, FlexDeck, and Heart Rate Zone Training are registered trademarks, and Sport Training, Heart Rate Hill, Heart Rate Interval, Extreme Heart Rate, Zone Training+, InstaPace, ZerOut, MaxTime, Lifepulse, Intelli, Ergo, Your Zone, Power Factor Plus, Lifespring, Everwax, and Custom Plus are trademarks of Brunswick Corporation. Polar is a registered trademark of Polar Electro, Inc. Cardio Theater is a registered trademark of Cardio Theater Holdings and a wholly owned subsidiary of ClubCom corporation. Broadcast Vision is a trademark of Broadcast Vision, Inc. FitLinxx is a trademark of the Integrated Fitness Corp. Any use of these trademarks, without the express written consent of Life Fitness or the corresponding companies is forbidden.

This Operation Manual describes the functions of the following products:

Life Fitness treadmills:

91Ti, 90T

See "Specifications" in this manual for product specific features.

Statement of Purpose: The treadmill is an exercise machine that enables users to walk or run, in place, on a moving surface.

Health-related injuries may result from incorrect or excessive use of exercise equipment. Life Fitness **STRONGLY** recommends seeing a physician for a complete medical exam before undertaking an exercise program, particularly if the user has a family history of high blood pressure or heart disease; or is over the age of 45; or smokes, has high cholesterol, is obese, or has not exercised regularly in the past year. Life Fitness also recommends consulting a fitness professional on the correct use of this product.

If, at any time while exercising, the user experiences faintness, dizziness, pain, or shortness of breath, he or she must stop immediately.

Des problèmes de santé peuvent être causés par une utilisation incorrecte ou excessive de l'équipement. Life Fitness conseille **VIVEMENT** de consulter un médecin pour subir un examen médical complet avant de commencer tout programme d'exercice, et tout particulièrement si l'utilisateur a des antécédents familiaux d'hypertension ou de troubles cardiaques, ou s'il a plus de 45 ans, s'il fume, s'il a du cholestérol, s'il est obèse ou n'a pas fait d'exercice régulièrement depuis un an. Life Fitness recommande également de consulter un professionnel du conditionnement physique pour savoir comment utiliser correctement ce produit.

Si, pendant l'utilisation de l'appareil, l'utilisateur ressent un malaise, des vertiges, des douleurs ou des difficultés à respirer, il doit s'arrêter immédiatement.

1 GETTING STARTED

1.1 IMPORTANT SAFETY INSTRUCTIONS

Read all instructions before using the treadmill.

- **DANGER:** To reduce the risk of electrical shock, always unplug this Life Fitness product before cleaning or attempting any maintenance activity.
- **WARNING:** To reduce the risk of burns, fire, electric shock, or injury, it is imperative to connect each product to a properly grounded electrical outlet.
- Never operate a Life Fitness product if it has a damaged power cord or electrical plug, or if it has been dropped, damaged, or even partially immersed in water. Contact Life Fitness Customer Support Services.
- Position this product so that the power cord plug is accessible to the user
- Keep the power cord away from heated surfaces. Do not pull the equipment by the powercord or use the cord as a handle. Do not run the power cord underneath, or along the side, of the treadmill.
- If the electrical supply cord is damaged, it must be replaced by the manufacturer, an authorized service agent, or a similarly qualified person to avoid a hazard.
- Do not use this product in areas where aerosol spray products are being used or where oxygen is being administered. Such substances create the danger of combustion and explosion.
- Always follow the console instructions for proper operation.
- Close supervision is necessary when used near children, invalids or disabled persons.
- Do not use this product outdoors, near swimming pools or in areas of high humidity.
- Never operate a Life Fitness product with the air openings blocked. Keep air openings free of lint, hair, or any obstructing material.
- Never insert objects into any opening in this product. If an object should drop inside, turn off the power, unplug the power cord from the outlet, and carefully retrieve it. If the item cannot be reached, contact Life Fitness Customer Support Services.
- Never place liquids of any type directly on the unit, except in an accessory tray or holder. Containers with lids are recommended.
- Wear shoes with rubber or high-traction soles. Do not use shoes with heels, leather soles, cleats or spikes. Make sure no stones are embedded in the soles.
- Keep all loose clothing, shoelaces, and towels away from moving parts.
- Do not use this product in bare feet.
- Do not reach into, or underneath, the unit or tip it on its side during operation.
- Keep the area six feet (two meters) by three feet (one meter) behind the treadmill clear of any obstructions, including walls, furniture, and other equipment.

- Handrails may be held to enhance stability as needed, but are not for continuous use.
- Never mount or dismount the treadmill while the running belt is moving. Use the handrails whenever additional stability is required. In case of an emergency, such as tripping, grasp the handrails, and place the feet on the side platforms.
- Never walk or jog backwards on the treadmill.
- An immobilized treadmill cannot be operated. The main motor, incline, and waxer are all disabled. To immobilize the 91Ti treadmill, set the display to read “SELECT WORKOUT”. Press the STOP key twice to do so if this message does not appear in the MESSAGE CENTER. Then, hold down the SPEED DOWN key, and press the STOP key. The console for the immobilized treadmill displays “IMMOBILIZED” in the MESSAGE CENTER. To restore operation, repeat the step of holding down the SPEED DOWN key and pressing the STOP key. To immobilize the 90T model treadmill, hold down the TIME DOWN key, and press the STOP key. The console for the immobilized treadmill shows three horizontal lines in each of the data display windows. To restore normal operation, repeat the step of holding down the TIME DOWN key and pressing the STOP key.
- Use this appliance only as it is intended, according to this manual. Do not use attachments not recommended by the manufacturer.
- Always wear the emergency stop clip when using the treadmill.

SAVE THESE INSTRUCTIONS FOR FUTURE REFERENCE.

1 POINT DEDÉPART

1.1 CONSIGNES DE SÉCURITÉ IMPORTANTES

Pour réduire les risques de décharges électriques, l'appareil Life Fitness doit toujours être débranché avant tout nettoyage ou travail d'entretien.

Pour réduire les risques de brûlures, d'incendies, de décharges électriques ou de blessures, tout appareil doit être branché impérativement sur une prise électrique correctement mise à la terre.

- Pour d brancher l'appareil, coupez l'alimentation au niveau de l'interrupteur de marche/arrêt, puis retirez la fiche de la prise électrique.
- Ne faites jamais fonctionner d'appareil Life Fitness dont le cordon d'alimentation ou la fiche seraient abîmés, qui aurait fait une chute ou qui aurait été endommagé ou partiellement plongé dans l'eau. Contactez le service après-vente de Life Fitness.
- Placez ce produit de manière à ce que l'utilisateur puisse accéder à la fiche du cordon d'alimentation.
- Maintenez le cordon d'alimentation à l'écart des surfaces chaudes. Ne tirez pas l'appareil par son cordon et n'utilisez pas celui-ci comme une poignée. Ne faites pas passer le cordon sur le sol, sous le tapis roulant, ni le long de l'appareil.
- Si le cordon d'alimentation électrique est endommagé, il doit être remplacé par le fabricant, par un réparateur agréé ou par une personne qualifiée afin d'éviter tout danger.
- N'utilisez pas ce produit dans des zones où vous utilisez des aérosols ou administrez de l'oxygène. De telles substances pourraient entraîner des risques d'incendie et d'explosion.
- Pour un fonctionnement correct, suivez toujours les instructions de la console.
- Une surveillance étroite est nécessaire en cas d'utilisation par des enfants, des personnes invalides ou handicapées.
- N'utilisez pas ce produit à l'extérieur, près d'une piscine ou dans endroits très humides.
- Ne faites jamais fonctionner de produit Life Fitness dont les bouches d'aération seraient bloquées. Maintenez-les exemptes de peluches, de cheveux ou de toute obstruction.
- N'insérez jamais d'objet dans les ouvertures de cet appareil. Si un objet tombe dedans, coupez l'alimentation électrique, débranchez le cordon de la prise et récupérez-le avec précaution. Si vous ne pouvez pas l'atteindre, consultez le service après-vente de Life Fitness.
- Ne placez jamais de liquides d'aucune sorte directement sur l'appareil, sauf si vous disposez d'un support ou d'un plateau pour accessoires. Il est recommandé d'utiliser des conteneurs munis d'un couvercle.
- Portez des chaussures avec semelles en caoutchouc ou antidérapantes. N'utilisez pas de chaussures à talons, de semelles en cuir ou à crampons. Assurez-vous qu'aucun caillou ne s'est incrusté dans les semelles.

- Maintenez les vêtements lâches, les lacets et les serviettes à l'écart des pièces en mouvement.
- N'utilisez pas cet appareil sans chaussures.
- Ne placez pas les mains sous ou dans l'appareil, et ne le renversez pas sur le côté pendant le fonctionnement.
- Derrière le tapis roulant, conservez une zone de 1,80 m sur 1 m libre de toute obstruction (aucun mur, meuble ou autre appareil).
- Les barres latérales peuvent servir à améliorer la stabilité, le cas échéant, mais elles ne sont pas conçues pour être utilisées de façon continue.
- Ne montez jamais sur le tapis roulant et n'en descendez jamais tandis qu'il tourne. Le cas échéant, utilisez les barres latérales pour augmenter votre stabilité.
- Ne marchez et ne courez jamais à l'envers sur ce tapis roulant.
- Il est impossible de faire fonctionner un tapis immobilisé. Le moteur principal, la pente et le cireur sont désactivés. Pour immobiliser le tapis, réglez l'affichage de manière à obtenir « SÉLECTIONNER EXERCICE » Appuyez deux fois sur la touche STOP pour cela si ce message n'apparaît pas au niveau du CENTRE DES MESSAGES. Maintenez ensuite la flèche VITESSE vers le BAS enfoncée et appuyez sur la touche STOP. La console du tapis immobilisé affiche « IMMOBILISÉ » dans le CENTRE DES MESSAGES. Pour reprendre le fonctionnement normal, maintenez à nouveau la flèche VITESSE vers le BAS enfoncée et appuyez sur STOP.
- Cet appareil ne doit être utilisé que selon l'usage pour lequel il est conçu, conformément au présent manuel. N'utilisez pas d'accessoires non conseillés par le fabricant.
- Vous devez toujours porter l'agrafe d'arrêt d'urgence lorsque vous utilisez le tapis de course.

CONSERVEZ CES INSTRUCTIONS POUR USAGE ULTÉRIEUR.

1.2 SETUP

Read the Operation Manual before setting up the Life Fitness treadmill. Place the treadmill where it will be used before beginning the setup procedure.

ELECTRICAL POWER REQUIREMENTS

The Life Fitness treadmill is intended for use on a normal 120-Volt electrical circuit in the United States and Canada. The following table provides the current rating for this product based on supply voltage. Make sure that this treadmill model supports the proper line voltage for the installation location before plugging it into the outlet.

Supply Voltage (VAC)	Frequency (Hz)	Rated Current (Amps)
100	50 / 60	12
120	50 / 60	12
200	50 / 60	6
220	50 / 60	6
230	50 / 60	6
240+	50 / 60	6

GROUNDING INSTRUCTIONS

This Life Fitness product must be properly grounded. If the unit malfunctions or breaks down, proper grounding provides a path of least resistance for the electric current, which reduces the risk of shock to anyone touching or using the equipment. Each unit is equipped with an electrical cord, which includes an equipment grounding conductor and a grounding plug. The plug must be inserted into an outlet that has been properly installed and grounded in accordance with all local codes and ordinances.

A temporary adapter **MUST NOT BE USED** to connect this plug to a two-pole receptacle in North America. If a properly grounded, 20-amp outlet is not available, one must be installed by a qualified electrician. Models drawing 16 amps or more must be installed on a dedicated line

ILEST ABSOLUMENT INTERDIT d'employer un adaptateur temporaire pour brancher cette fiche sur une prise à deux pôles en Amérique du Nord. Si aucune prise de 20 A correctement mise à la terre n'est disponible, il convient d'en faire installer une par un électricien qualifié. Les modèles utilisant 16 A ou plus doivent être installés sur des lignes qui leur sont réservées.

DANGER: A risk of electrical shock may result from improper connection of the equipment-grounding conductor. Check with a qualified electrician if in doubt as to proper grounding technique. DO NOT modify the plug provided with the product. If it will not fit an electrical outlet, have a proper outlet installed by a qualified electrician.

DANGER: Un branchement incorrect du conducteur de mise à la terre peut entraîner des risques de décharge électrique. Consultez un électricien si des doutes subsistent quant à la technique de mise à la terre. NE MODIFIEZ PAS la fiche fournie avec l'appareil. Si elle ne s'adapte pas à une prise, faites en installer une correcte par un électricien qualifié.

REMOVING AND REPLACING THE WAX BAG

The wax lubrication system is a standard feature on the 91Ti model and international 90Tmodel. Treadmills with waxers are equipped to monitor wax levels automatically. On the 91Ti, when the wax bag is six-percent full, the console displays “NOTIFY MAINTENANCE – WAXER NEEDS REFILL”. When the bag is empty, the treadmill shuts down, and the console displays, “NOTIFY MAINTENANCE – WAXER EMPTY”. On a waxer-equipped 90Tmodel, when the wax bag is six-percent full, the DATA DISPLAY windows show “Err9”. When the wax bag is empty, the treadmill shuts down and the DATADISPLAYwindows show, “Err10”.

The wax bag is installed underneath the motor pan of the treadmill. To make replacing the bag as easy as possible, use the UP LEVEL ARROW key to elevate the treadmill to the 15 percent incline.

Before starting the procedure, turn the power off (“I”) at the ON/OFF switch, and unplug the unit from the electrical outlet.

Open the wax tray: Pull out the three push rivets (A) that fasten the front edge of the wax tray (B) to the bottom of the motor pan (C). If necessary, use a flat-edge screw driver to pry off the rivets. The rivets are reusable. Set down the front edge of the wax tray with the waxbag on top of it.

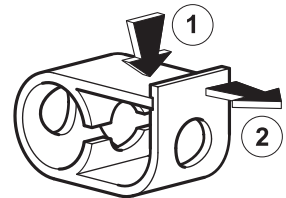

Note: The rear edge of the wax tray is attached to the motor pan during factory assembly.

Detach the old wax bag: Remove the motor cover. Engage (1) the wax bag hose clamp (D) to prevent any wax residue from seeping out of the bag. Then, gently work the wax bag hose off of the barbed nozzle on the wax pump inlet hose located inside the motor compartment. Open (2) the hose clamp, and slide it off. Discard the old wax bag.

Attach the hose clamp to the new wax bag: Slide the hose clamp (D) over the end of the new wax bag outlet hose (E). Position the clamp approximately three inches from the end of the hose and clamp it (1) onto the wax bag hose to prevent spillage.

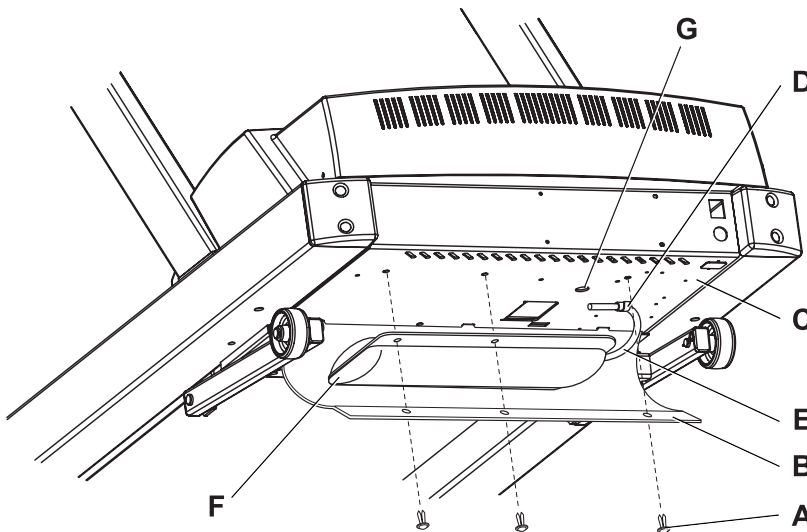

Position the wax bag under the frame: Place the wax bag (F) on top of the wax tray, so that the wax bag is directly underneath the treadmill motor pan (C), the wax bag flange is facing out toward the front of the treadmill, and the wax bag hose is near the hole (G) at the bottom of the motor pan through which the hose will be fed in the next step.

Connect the wax bag hose to the pump inlet hose: Cut off the end of the wax bag hose (E) one half-inch from the end. Feed the hose through the hole (G) at the bottom of the motor pan, and slide it onto the barbed nozzle on the wax pump inlet hose located inside the motor compartment. Be sure to fully seat the wax bag hose onto the inlet hose. Release (2) the hose clamp (D).



CAUTION: Failure to release the hose clamp greatly shortens belt life.

MISE EN GARDE : la bride de serrage doit être relâchée sous peine de réduire de façon importante la durée de vie du tapis.

Close the wax tray: Align the wax tray: Align two holes of the wax bag flange with the two holes along the front edge of the wax tray (B) and the two holes at the bottom of the treadmill motor pan (C). Attach the wax tray and wax bag (F) to the motor pan with two of the push-rivets (A), simply by pushing each rivet upward through both sets of aligned holes. Once each rivet is pushed through the holes as far as possible, its front tip flares open to keep the tray and wax bag fastened to the motor pan. Push a third push-rivet through the remaining aligned holes in the wax tray and the bottom of the treadmill motor pan.

Inform the system that a new wax bag has been installed: Access the Manager's Configuration. For details, see Section 5.1, titled *Entering and Using the Manager's Configuration*. On the 91Ti model, scroll to the Refill Waxer System configuration setting. Press ENTER. The MESSAGE CENTER displays "REPAIR LOGGED" Press the CLEAR key three times to exit the Manager's Configuration. On the 90T model, select the Waxer System Installed configuration setting. Change the setting to "no" by pressing the SPEED DOWN ARROW key once. Then, change the setting to "yes" by pressing the SPEED UP ARROW key once. Press the STOP key once to exit the Manager's Configuration.

HOW TO POSITION AND STABILIZE THE LIFE FITNESS® TREADMILL

Following all safety instructions in Section 1.1, move the treadmill to the location in which it will be used. See Section 7, titled *Specifications*, for the dimensions of the footprint. Allow a distance of eight inches, or 21 centimeters, between the treadmill and other units on either side. Allow a distance of six feet, or two meters, from the rear of the treadmill to any object or surface.

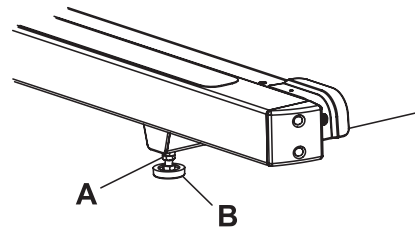

After placing the unit where it will be used, check its stability. If there is even a slight rocking motion or the unit is not stable, determine which stabilizing leg is not resting on the floor. To adjust, loosen the JAM NUT (A), and turn the STABILIZING LEG (B) until the rocking motion ceases, and both stabilizing legs rest firmly on the floor. Retighten the JAM NUT.

NOTE: It is extremely important that the stabilizing leg be correctly adjusted for proper operation. An unbalanced unit may cause striding belt misalignment.

POWER SWITCH

Located on the front panel at the base of the treadmill, the ON/OFF switch has two positions: "1" (one) for ON and "0" (zero) for OFF.

IMMOBILIZING THE TREADMILL

An immobilized treadmill cannot be operated. The main motor, incline, and waxer are all disabled. To immobilize the 91Ti treadmill, set the display to read "SELECT WORKOUT". Press the STOP key twice to do so if this message does not appear in the MESSAGE CENTER. Then, hold down the SPEED DOWN key, and press the STOP key. The console for the immobilized treadmill displays "IMMOBILIZED" in the MESSAGE CENTER. To restore operation, repeat the step of holding down the SPEED DOWN key and pressing the STOP key. To immobilize the 90T model treadmill, hold down the TIME DOWN key, and press the STOP key. The console for the immobilized treadmill shows three horizontal lines in each of the data display windows. To restore normal operation, repeat the step of holding down the TIME DOWN key and pressing the STOP key.

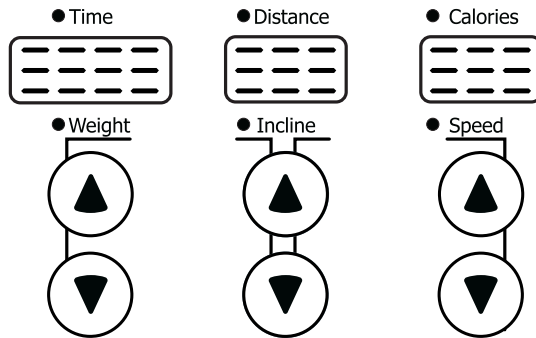

The DATA DISPLAY on a Model 90T treadmill

After installing and levelling the treadmill, check the belt to ensure that it is tracking properly. First, plug the power cord into an appropriate outlet. See Electrical Requirements at the beginning of this section for details. Then, turn the treadmill ON (“I”).

Stand on the siderails of the treadmill and straddle the belt. Press the SPEED UP ARROW key, and increase the speed to 4.0 mph (6.4 kph).

If the striding belt moves to the right while it is running, have a second person turn the right tension bolt a quarter-turn clockwise, and then turn the left tension bolt (A) a quarter-turn counterclockwise.

See the illustration below. This action sets the striding belt tracking back to center of the roller. If the striding belt moves to the left, turn the left tension bolt a quarter-turn clockwise and then turn the right tension bolt a quarter-turn counter-clockwise to start the striding belt tracking back to center of roller.

Repeat these adjustments until striding belt appears centered. Allow the belt to continue running for several minutes to be sure that the tracking is stabilized.

NOTE: Do not exceed one full turn of the adjusting screws in either direction. If, after one full turn, the belt does not track properly, contact Customer Support Services. The phone numbers are listed in Section 6.7, titled How to Obtain Product Service.

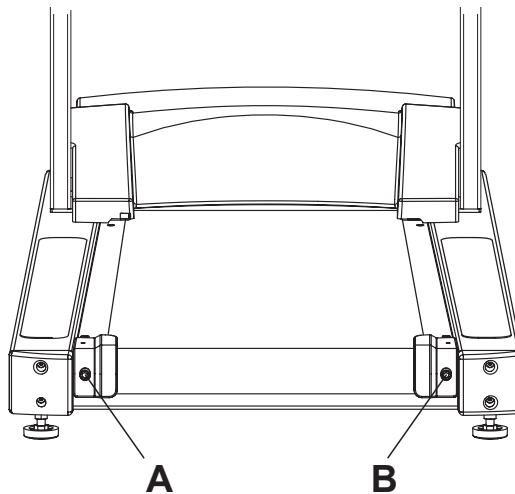

FITNESS NETWORKING AND ENTERTAINMENT

A network port on the console of the Life Fitness treadmill allows the unit to be connected to a fitness entertainment system and/or a network, such as the FitLinxx™ interactive fitness network.

Fitness network: The network connection enables the console to upload user workout statistics to a fitness network database or to download remotely stored information, such as a pre-set workout program. See Section 4.2, titled Using the Workouts, for information on logging onto a network

Entertainment: The network connection enables the console to power a third-party receiver for use with a service such as the Cardio Theater® entertainment system or the BroadcastVision™ entertainment system.

This port is located inside the console assembly. To access it, remove the left accessory tray. See Section 6.5 for details. Then, remove the console assembly cover door. Locate the port and plug in the network cable. Re-attach the console assembly cover door and the accessory tray. Any use of the port for other than its intended purpose could void the product warranty.

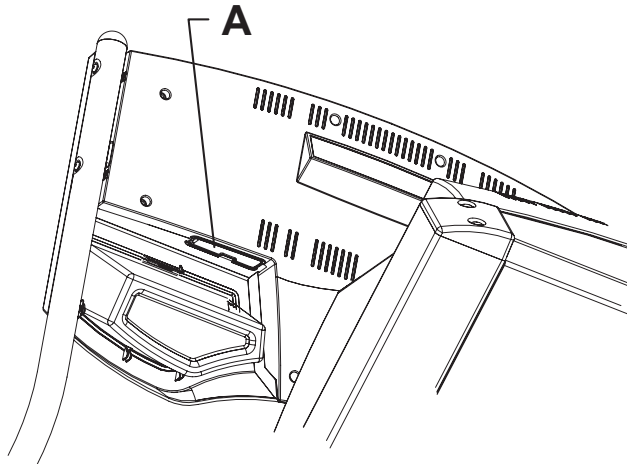

POWER CORD ROUTING

The power cord run is attached to the treadmill motor pan. On units sold in the United States, the cord runs out from the front panel of the motor pan on the right side.

On units sold elsewhere, the cord plugs into the bottom of the motor pan near the front, user left corner. It is held in place by a clip.

Always run the power cord in front of the treadmill to plug it in. Do not run the power cord underneath, or along the side, of the unit.

2 THE DISPLAY CONSOLE

2.1 DISPLAY CONSOLE OVERVIEW

The computerized display console on the treadmill allows the user to tailor a workout to personal fitness abilities and goals and to monitor progress. With this easy-to-use console, the user can track fitness improvement from one workout to the next.

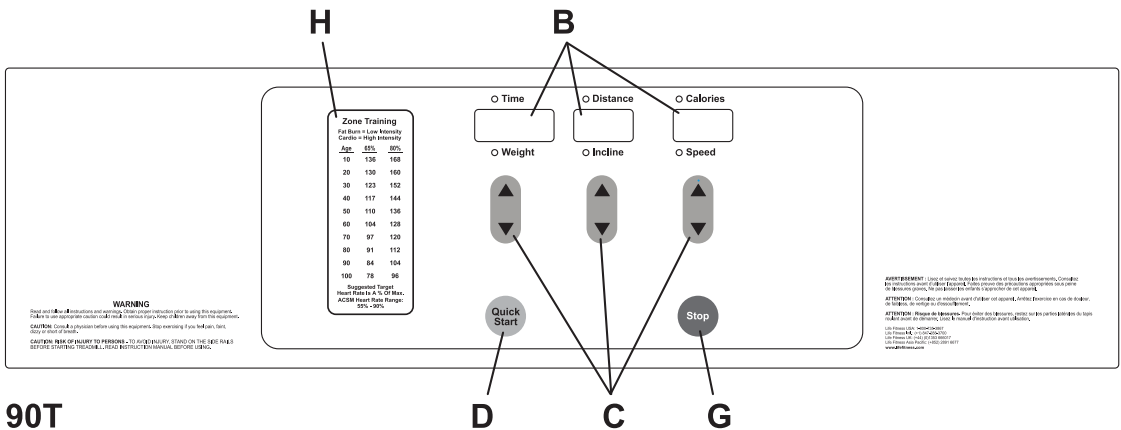
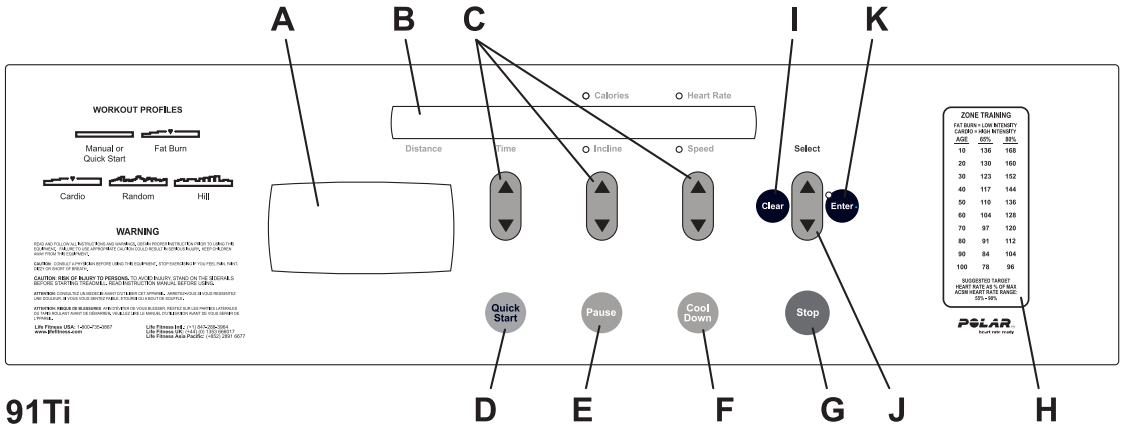

2.2 DISPLAY CONSOLE DESCRIPTIONS

A WORKOUT PROFILE window (91Ti only): This window displays shapes, made of columns of lights, that represent the incline and levels of intensity for a workout-in-progress. The height of the column furthest to the left is proportional to the current level of incline and intensity. During a **FAT BURN*** or **CARDIO*** workout, which requires the use of the Lifepulse system sensors or the Polar heart rate chest strap, the WORKOUT PROFILE window displays a heart shape to request the user's heart rate signal. If the console does not detect a signal, the MESSAGE CENTER displays the prompt, "NEED HEART RATE - PLACE HANDS ON SENSORS OR USE TELEMETRY STRAP". If the console does not receive the signal within three minutes, the workout automatically is converted to a **MANUAL** program.

**These workouts are available on the 91Ti model only.*

- B** MESSAGE CENTER (91Ti only): This window displays step-by-step instructions for setting up a workout. During a workout, it displays statistics about the progress of the workout:
- **Calories:** the total number of calories burned since beginning the workout.
 - **Time:** the number of minutes elapsed since beginning the workout.
 - **Distance:** the total distance traveled.
 - **Incline:** the selected incline level of the workout.
 - **Heart Rate:** the detected heart rate if the user is grasping the LifePulse system sensors or wearing the Polar heart rate chest strap.
 - **Speed:** the user's speed.
 - **Calories per Hour:** the rate of calories burned per hour.
 - **Pace:** the rate of minutes per mile or kilometer.
 - **Watts:** effort level in Watts. The Watt is a unit of power output or the expression of the mechanical rate of work.
 - **Mets:** effort level in Mets. The Met is an expression of the rate of work for the human body, or a metabolic equivalent; one Met is approximately equal to the metabolism of a person at rest.
 - **Distance Climbed:** a calculation of feet or meters based on the speed and incline.
- C** DATA DISPLAY (90T only): During a workout, these three windows display statistics about the progress of the workout:
- **Time:** the number of minutes elapsed since beginning the workout.
 - **Distance:** the total distance traveled.
 - **Calories:** the total number of calories burned since beginning the workout.
 - **Incline:** the selected incline level of the workout.
 - **Speed:** the user's speed.
 - **Heart Rate:** the detected heart rate if the user is grasping the LifePulse system sensors or wearing the Polar heart rate chest strap.

After a new workout has been underway for 12 seconds, the left DATA DISPLAY window flashes a default weight value of 150 pounds (68 kg), indicating that the computer is requesting the user's weight to calculate the number of calories burned. Use the WEIGHT ARROW keys to enter the correct weight. If no weight is entered, the computer uses the default value to calculate calories burned.

[†] Defined by the American College of Sports Medicine's "Guidelines for Exercise Testing and Prescription" as equal to 220 minus an individual's age.

* Target Heart Rate (THR) is a percentage of the theoretical maximum. For example, a 40-year-old user's THR for the **FAT BURN** workout is 117. This workout targets 65 percent of the maximum, so the equation would be $(220-40) \times .65 = 117$.

TIME, INCLINE, and SPEED ARROW keys (91Ti only): Press these keys to increase or decrease the workout time, the incline of the treadmill deck, or the striding belt speed. The MESSAGE CENTER displays the input data in sections located just above the keys.

TIME/WEIGHT, INCLINE, and SPEED ARROW keys (90T only): Press these keys to increase or decrease the workout time, the incline of the treadmill deck, or the striding belt speed. The DATA DISPLAY shows the input data in sections located just above the keys.

- D** QUICK START: Press this key to begin a manual workout immediately. Once the workout is in progress, use the ARROW keys to change the workout settings as desired.
- E** PAUSE (91Ti only): Press this key to stop the belt and hold the current workout. Continue the workout by pressing the ENTER key. When the pause duration is reached, the console resets and displays a prompt to set up a new workout.
- F** COOL DOWN (91Ti only): Press this key to begin an automatically customized workout cool-down.
- G** STOP: Press this key to stop the belt and the workout. The MESSAGE CENTER then displays a summary of the workout, including total time elapsed, total distance traveled, and total calories burned. Pressing STOP a second time causes the MESSAGE CENTER to prompt the user for a new workout setup.
- H** ZONE TRAINING HEART RATE CHART: Consult this chart to select a target heart rate* for a specific age and percentage of the theoretical maximum heart rate. For more information, see Section 3, titled *Heart Rate Zone Training Exercise*.
- I** CLEAR (91Ti only): Press this key, when programming a workout, to clear incorrect data, such as weight or age, before pressing the ENTER key. Pressing the key during a workout places the workout in PAUSE mode. To resume the workout, press the ENTER key. Press the CLEAR key twice in succession to terminate the workout. When the treadmill is in PAUSE mode, the MESSAGE CENTER displays a count-down clock. Once this clock times out, the workout terminates. See the Settings topic in the Section 5, titled *Mangager.s Configuration*, for information on reducing or increasing the pause duration.
- J** SELECT ARROW keys (91Ti only): Use these keys to enter data, cycle through and select workouts, and change the target heart rate during a FAT BURN or CARDIO workout.
- K** ENTER (91Ti only): Press this key to confirm entries of workout setup values displayed in the MESSAGE CENTER

2.3 EMERGENCY STOP SYSTEM

A cord with a clip is attached to this magnetized key. Before starting a workout, attach the clip to clothing. To stop the striding belt on the treadmill during an emergency, pull the cord, removing the key from the console. Replace the key to reset the system.



2.4 READING RACK

The display console design includes a built-in reading rack allowing a book or magazine to be supported during the workout.

2.5 ACCESSORY TRAYS

The accessory trays (A), located on either side of the display console, are removable. They should be cleaned periodically. See Chapter 6, titled *Service and Technical Data*, for details.

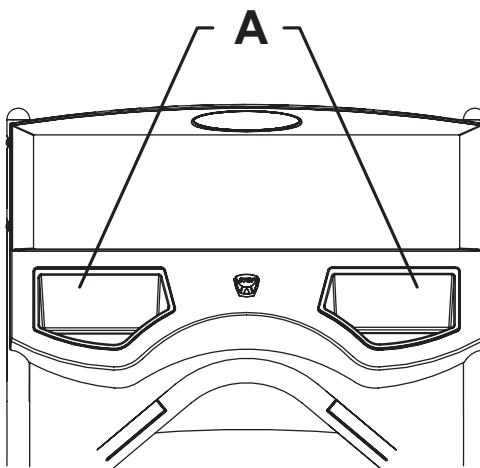

3 HEART RATE ZONE TRAINING EXERCISE

3.1 WHY HEART RATE ZONE TRAINING EXERCISE?

Research shows that maintaining a specific heart rate while exercising is the optimal way to monitor the intensity of a workout and to achieve maximum results. That is the idea behind the Life Fitness heart rate zone training approach to exercise.

Zone training identifies an exerciser's ideal heart rate range, or zone, for burning fat or increasing cardiovascular fitness. The values within the zone depend on the workout.

Note: Consulting a fitness trainer is recommended for defining specific fitness goals and designing a workout program.

ZONE TRAINING		
FAT BURN = LOW INTENSITY		
CARDIO = HIGH INTENSITY		
AGE	65%	80%
10	136	168
20	130	160
30	123	152
40	117	144
50	110	136
60	104	128
70	97	120
80	91	112
90	84	104
100	78	96

SUGGESTED TARGET
HEART RATE AS % OF MAX
ACSM HEART RATE RANGE:
55% - 90%

The Model 91Ti treadmill features exclusive workouts designed to take full advantage of the benefits of heart rate zone training exercise: **FAT BURN** and **CARDIO**. Each workout offers different benefits, as discussed in Section 4, titled *The Workouts*.

During one of these workouts, grasp the Lifepulse system sensors, or wear the Polar heart rate chest strap to enable the on-board computer to monitor the heart rate. The computer automatically adjusts the resistance level to maintain the target heart rate* based on the actual heart rate. To change the target heart rate during a workout, use the SELECT ARROW keys.

Although the Model 90T does not offer the **FAT BURN** and **CARDIO** workouts, it is equipped with the LifePulse system sensors and Polar telemetry heart rate monitoring. The Polar heart rate chest strap is sold separately for both the Model 91Ti and the Model 90T.

* Target Heart Rate (THR) is a percentage of the theoretical maximum (HRmax). A 40-year-old user's recommended THR for the HEART RATE HILL workout is 144, or 80 percent of the maximum; so the equation would be $(220-40) \times .80 = 144$.

3.2 HEART RATE MONITORING

THE LIFEPUULSE™ DIGITAL HEART RATE MONITORING SYSTEM

To use the treadmill's Lifepulse™ system to check the heart rate during a workout, grasp the sensors (A) on the Ergo™ handlebar. Maintain contact with all four sensors throughout the workout to obtain a heart rate reading. The console displays a heart rate within 20 to 30 seconds of contact with the sensors.

It is not recommended to grasp the sensors at speeds above 4.5 MPH, or 7.2 KPH. For these speeds, the use of a heart rate chest strap is recommended.

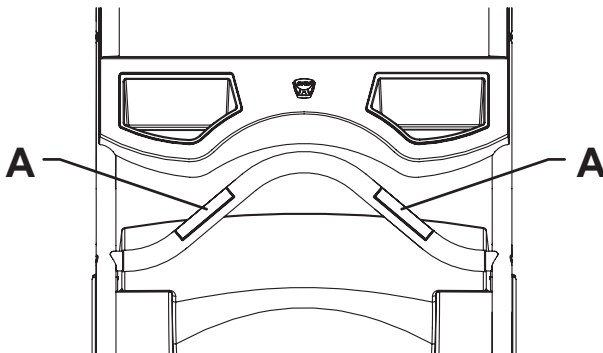

THE POLAR® TELEMETRY HEART RATE MONITORING CHEST STRAP

The Life Fitness treadmill is equipped with Polar telemetry, a heart rate monitoring system in which electrodes, pressed against the skin, transfer heart rate signals to the treadmill console. These electrodes are attached to a chest strap that the user wears during the workout. The chest strap is optional. For information on ordering, see Section 6.7, titled *How to Obtain Product Service*.

See the diagram below for correct positioning of the strap. The electrodes (A), which are the two grooved surfaces on the underside of the strap, must remain wet to transmit accurately the electrical impulses of the heart back to the receiver. Moisten the electrodes. Then, secure the strap as high under the chest muscles as possible. The strap should be snug, but comfortable enough to allow for normal breathing.

The transmitter strap delivers an optimal heart rate reading when the electrodes are in direct contact with bare skin. However, it functions properly through a thin layer of wet clothing. If it becomes necessary to re-moisten the chest strap electrodes, grasp the center of the strap, pull it away from the chest to expose the two electrodes, and re-moisten them.

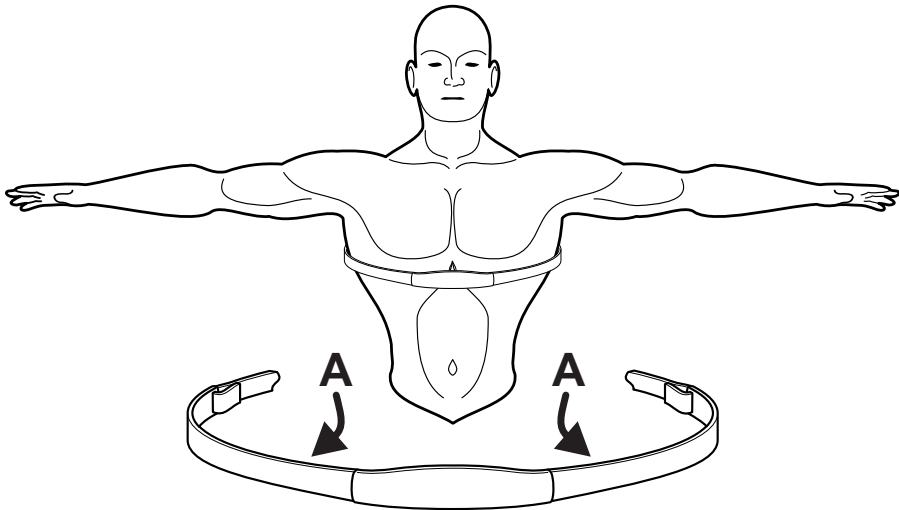

4 THE WORKOUTS

4.1 WORKOUT OVERVIEWS

The following workouts are preprogrammed for the Life Fitness treadmill. Access them by pressing the SELECT ARROW keys.

MANUAL is a workout in which the intensity level does not change automatically. It is available on the 91Ti and 90T models. On the 91Ti model, a **MANUAL** workout can be programmed to target certain type of goals other than the default time goal. See the topic titled *Selecting an Alternate Goal Type* in the following section.

The following workouts are available on the 91Ti model only:

HILL is an interval training workout. Intervals are periods of intense aerobic exercise separated by regular periods of lower-intensity exercise.

RANDOM is an interval training workout of constantly changing intensity levels that occur in no regular pattern or progression.

FAT BURN is a lower-intensity workout for burning the body's fat reserves. The user grasps the Lifepulse system sensors continuously or wears a Polar heart rate chest strap. The program adjusts the intensity level, based on the actual heart rate, to maintain the target heart rate* of 65 percent of the theoretical maximum†.

CARDIO is a higher-intensity workout for more fit users, emphasizing cardiovascular benefits and maximum fat burning. The user grasps the Lifepulse system sensors continuously or wears a Polar heart rate chest strap. The program adjusts the intensity level, based on the actual heart rate, to maintain the target rate of 80 percent of the theoretical maximum.

4.2 USING THE WORKOUTS

LOGGING ON TO A NETWORK (91Ti ONLY)

If the Life Fitness treadmill is connected to a fitness network, the console downloads personal, pre-configured workouts, making it unnecessary to set up a workout manually. To start a workout with networking enabled, first step on the treadmill. The MESSAGE CENTER displays a prompt to log on with a personal ID number. Press ENTER. Select each digit of the number by using the SELECT ARROW keys, and press ENTER. Repeat this step for all digits of the ID number. Then, when prompted by the MESSAGE CENTER, begin the workout

† Defined by the American College of Sports Medicine's "Guidelines for Exercise Testing and Prescription" as equal to 220 minus an individual's age.

* Target Heart Rate (THR) is a percentage of the theoretical maximum (HRmax). For example, a 40-year-old user's recommended THR for the FAT BURN workout is 117, or 65 percent of the maximum, so the equation would be $(220 - 40) * .65 = 117$.

SETTING UP THE NETWORKS WITHOUT NETWORKING ENABLED

To select a workout: At the MESSAGE CENTER prompt to select a workout, press the SELECT ARROW keys repeatedly to scroll through displayed workout options. Press ENTER when the name of the desired workout appears.

To enter setup information: The MESSAGE CENTER displays prompts for workout setup information, such as weight and desired speed. At each prompt, use the SELECT ARROW keys to scroll to the desired value, and press ENTER.

Then, when prompted by the MESSAGE CENTER, begin the workout.

To change workout information during a workout: Use the TIME, INCLINE, and SPEED ARROW keys to change attributes while the workout is in progress.

To stop a workout before the end of the duration: Press the STOP key. A chart that lists all the steps for setting up each workout appears later in this section.

SETTING UP A WORKOUT (90T ONLY)

To start the treadmill: Simply press QUICK START or the SPEED UP ARROW key. As the treadmill begins moving, press the SPEED UP ARROW key to reach the desired speed.

To increase the incline: Press the INCLINE UP ARROW key.

To set the weight: After a new workout has been underway for 12 seconds, the left DATA DISPLAY window flashes a default weight value of 150 pounds (68 kg), indicating that the computer is requesting the user's weight to calculate the number of calories burned. Use the WEIGHT ARROW keys to enter the correct weight, and then press the QUICK START key to accept the entered weight. If no weight is entered, the computer uses the default value to calculate calories burned.

To stop a workout before the end of the duration: Press the STOP key.

USING QUICK START

Press the QUICK START key to start the treadmill. Use the INCLINE and SPEED ARROW keys to adjust those settings.

On the 91Ti model: After a new workout has been underway for 12 seconds, the MESSAGE-CENTER displays a prompt for the user's weight. Use the SELECT ARROW keys to select the actual weight, and then press the QUICK START key to accept the entered weight. Doing so enables the treadmill computer to calculate calories burned accurately.

LIFE FITNESS TREADMILL 91Ti WORKOUT SETUP STEPS

MANUAL

Select MANUAL
Enter weight
Enter time
Enter incline
Enter speed
Begin workout

FAT BURN**

Select FAT BURN
Enter weight
Enter time
Enter age
Enter THR*
Enter speed
Begin workout

RANDOM

Select RANDOM
Enter weight
Enter time
Enter level
Enter speed
Begin workout

CARDIO**

Select CARDIO
Enter weight
Enter time
Enter age
Enter THR*
Enter speed
Begin workout

HILL

Select HILL
Enter weight
Enter time
Enter level
Enter speed
Begin workout

** Target Heart Rate (THR) is a percentage of the theoretical maximum. For example, a 40-year-old user's THR for the CARDIO workout is 144. This workout targets 80 percent of the maximum, so the equation would be $(220-40) \cdot 80 = 144$.*

*** This workout requires the user to grasp the Lifepulse system sensors or wear the Polar heart rate chest strap.*

On the 90T model: After a new workout has been underway for 12 seconds, the left DATA DISPLAY window flashes a default weight value of 150 pounds (68 kg). Use the WEIGHT ARROW key to adjust the value to the actual weight, and then press the QUICK START key to accept the entered weight. Doing so enables the treadmill computer to calculate calories burned accurately.

SELECTING A LEVEL (91Ti ONLY)

The steps for setting up a **HILL** or **RANDOM** workout include selecting a level. The word "level" refers to a range of incline percentages. The treadmill features 20 levels, with Level 1 having the lowest average incline grade and Level 20 having the highest.

LEVEL	% Incline	LEVEL	% Incline
1	0.0 - 1.5	11	2.0 - 8.5
2	0.0 - 2.2	12	3.0 - 9.2
3	0.0 - 2.9	13	3.5 - 9.9
4	0.0 - 3.6	14	5.0 - 10.6
5	0.0 - 4.3	15	5.5 - 11.3
6	0.0 - 5.0	16	6.5 - 12.0
7	0.0 - 5.7	17	7.0 - 12.7
8	0.0 - 6.4	18	8.0 - 13.4
9	0.5 - 7.1	19	8.7 - 14.1
10	1.5 - 7.8	20	9.0 - 15.0

Within each level are seven incline percentages, or hills. During a workout, each hill appears in the WORKOUTPROFILE window as rows of light stacked in a column. The number of lit rows within a column corresponds to an incline percentage. For example, in Level 5, the lowest incline is 0.0 percent and is represented as one lit row. The highest incline, 4.3 percent, is represented by a column with all seven rows lit. In the **HILL** and **RANDOM** workouts, these varying hills occur for equal durations, as discussed in the **HILL** workout description. It is possible to change the level manually. To change levels during a workout, use the SELECT ARROW keys.

Using ZerOut™ Speed Control (91Ti ONLY) If, during a workout, a user decreases the speed to the minimum and continues to hold the SPEED DOWN ARROW key, the speed falls to 0 MPH, and the workout goes into pause mode.

SELECTING AN ALTERNATE GOAL TYPE (91Ti ONLY)

A **MANUAL** workout can be programmed to target certain type of goals other than a time goal:

- Calories
- Distance

The **Calories Goal** feature is designed to promote weight loss and weight control. The user sets a calorie goal during the workout setup. Once the goal is met, the workout automatically goes into a cool-down phase and ends afterward. To use this feature:

1. When prompted to select a workout, press the UP ARROW key repeatedly until "CUSTOM PLUS" appears. Press ENTER.
2. The MESSAGE CENTER displays "SELECT CUSTOM PLUS TYPE". Continue to press the UP ARROW key until the MESSAGE CENTER displays "CALORIES GOAL". Press ENTER.

3. Using the UP ARROW keys, enter the desired calorie goal value, which can range from 100 to 2000 calories. Press ENTER.
4. Using the UP ARROW keys, enter the weight. Press ENTER.
5. Using the UP ARROW keys, enter the speed. Press ENTER.
6. Begin the workout.

The **Distance Goal** feature is designed to build endurance. The user sets a distance goal during the workout setup. Once the goal is met, the workout automatically goes into a cool-down phase and ends afterward. To use this feature:

1. When prompted to select a workout, press the UP ARROW key repeatedly until "CUSTOM PLUS" appears. Press ENTER.
2. The MESSAGE CENTER displays "SELECT CUSTOM PLUS TYPE". Continue to press the UP ARROW key until the MESSAGE CENTER displays "DISTANCE GOAL". Press ENTER.
3. Using the UP ARROW keys, enter the desired distance goal value, which can range from .1 miles or kilometers to 50 miles or 100 kilometers. Press ENTER.
4. Using the UP ARROW keys, enter the weight. Press ENTER.
5. Using the UP ARROW keys, enter the speed. Press ENTER.
6. Begin the workout.

COOL-DOWN (91Ti ONLY)

Life Fitness' unique Cool-Down Protocol automatically customizes every cool-down based on each user's workout performance. Workout performance factors, such as speed, incline, duration, and heart rate, determine the duration and intensity of the cool-down.

4.3 WORKOUT DIRECTIONS

MANUAL

The **MANUAL** program sets an intensity level that does not change automatically. While the work-out is in progress, increase or lower the intensity level as desired, using the SPEED and/or INCLINE ARROW keys.

HILL (91Ti ONLY)

The Life Fitness-patented **HILL** workout offers a variety of configurations for interval training. Intervals are periods of intense cardiovascular exercise separated by regular periods of lower-intensity exercise. The WORKOUT PROFILE window represents these high and low intervals as columns of light, which together have the appearance of hills and valleys. The computerized interval training workout has been scientifically demonstrated to promote greater cardio respiratory improvement than steady-pace training.

The **HILL** workout goes through four phases, each marked by different intensity levels. The WORKOUT PROFILE window displays the progress of these phases. As noted in the descriptions below, the heart rate should be measured at two stages in the workout to gauge its effectiveness. Wear the chest strap or continuously grip the Lifepulse system sensors (91Ti only). The MESSAGE CENTER does not display a request for a heart rate measurement, as it does with **CARDIO** and **FAT BURN**.

- 1 **Warm-up** is a phase of low, gradually rising resistance, which brings the heart rate into the lower end of the target zone and increases respiration and blood flow to working muscles.
- 2 **Plateau** increases the intensity slightly, and keeps it steady, to bring the heart rate to the low end of the target zone. Check the heart rate at the end of this phase.
- 3 **Interval Training** is a series of increasingly steeper hills, alternating with valleys, or stints of recovery. The heart rate should rise to the high end of the target zone. Check the heart rate at the end of this phase.
- 4 **Cool-down** is a low-intensity phase that allows the body to begin removing lactic acid, and other exercise by-products, which build up in muscles and contribute to soreness.

TERRAIN (HILLS AND VALLEYS)

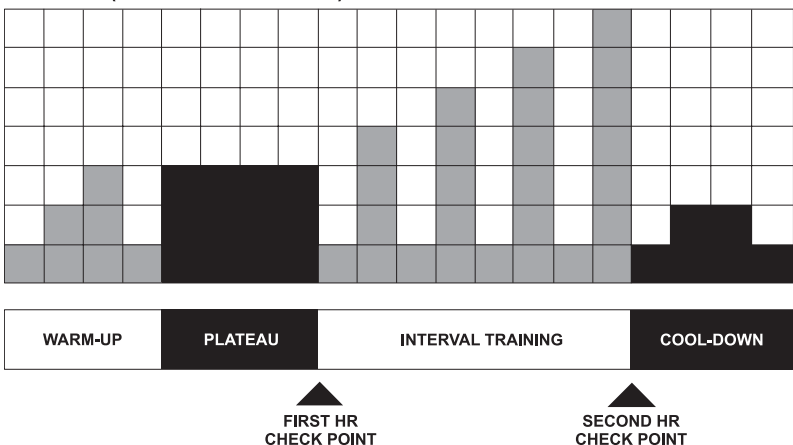

Each column, as seen in the WORKOUT PROFILE WINDOW and the chart above, represents one interval. The overall duration of the workout determines the length of each interval. Each workout is made up of 20 intervals, so the duration of each interval is equal to the duration of the entire workout divided by 20.

1 to 9 minutes: A workout with duration of less than 10 minutes is insufficient for the HILL program to complete all four phases adequately. The program, therefore, condenses a workout of this duration at various stages.

10 to 19 minutes: The interval durations initially are set at 30 seconds for a 10-minute workout. For every minute over 10, each interval increases by three seconds. A 15-minute workout consists of 20 intervals at 45 seconds each.

20 to 99 minutes: All intervals last 60 seconds. If the user adds minutes to the pre-set duration while the workout is in progress, the program adds hills and valleys that are identical to the first eight intervals of the Interval Training phase. This pattern repeats until the workout is completed.

RANDOM (91Ti ONLY)

The **RANDOM** program creates a terrain of hills and valleys that varies with each workout. More than one million different patterns are possible.

FAT BURN (91Ti ONLY)

The **FAT BURN** workout is designed to maintain a user's heart rate at 65 percent of the theoretical maximum[†] for optimal results. Throughout the workout, the user wears a chest strap or grasps the Lifepulse system sensors. If the user is not grasping the Lifepulse system sensors or wearing the Polar heart rate chest strap, the WORKOUT PROFILE WINDOW displays a heart shape, and the MESSAGE CENTER displays a prompt to grasp the sensors. The console continuously monitors and displays the heart rate, adjusting the intensity level of the treadmill to reach and maintain the target heart rate*. This system eliminates over- and under-training, and it maximizes the aerobic benefits of exercise by using the body's fat stores for fuel.

CARDIO (91Ti ONLY)

The **CARDIO** workout is virtually identical to **FAT BURN**; however the target heart rate is calculated at 80 percent of the theoretical maximum. The higher target promotes cardiovascular improvement by placing a heavier workload on the heart muscle.

NOTE: *Change the target heart rate for a **FAT BURN** or **CARDIO** workout at any time by using the **SELECT ARROW** keys.*

[†] Defined by the American College of Sports Medicine's "Guidelines for Exercise Testing and Prescription" as equal to 220 minus an individual's age.

* Target Heart Rate (THR) is a percentage of the theoretical maximum. For example, a 40-year-old user's THR for the FATBURN workout is 117. This workout targets 65 percent of the maximum, so the equation would be $(220-40) \times .65 = 117$.

5 THE MANAGER'S CONFIGURATION

5.1 ENTERING AND USING THE USER MENU

91Ti model: Press and hold down the PAUSE key, and press the CLEAR key twice. Continue to hold down the PAUSE key until the MESSAGE CENTER displays SERVICE MENU. Then, release the PAUSE key, press the QUICK START key. The MESSAGE CENTER displays "MANAGER'S CONFIG". Press ENTER. The MESSAGE CENTER then displays, in turn, each of the configuration settings. Use the TIME arrow keys to scroll through the list of settings, or allow the MESSAGE CENTER to scroll automatically through the options. To stop the automatic scrolling, press the PAUSE key. To resume the automatic scrolling, press the PAUSE key again. To select a displayed option, press the ENTER key.

The Manager's Configuration settings are listed on the following page in the order in which they appear in the MESSAGE CENTER display. Use the INCLINE or SPEED keys to change settings. In most cases, changing a setting means turning it on or off. See the table on the following page for more information.

To return to the workout setup state, press the CLEAR key repeatedly until the MESSAGE CENTER displays the prompt to set up a workout.

90Ti model: Press and hold down the TIME UP ARROW key, and press the STOP key twice. The DATA DISPLAY windows show "SETTINGS". Use the TIME ARROW keys to scroll through the displayed list of settings. Use the SPEED ARROW keys to change settings. See the table on the following page for detailed information about settings. To return to workout setup mode, press the STOP key once.

5.2 CONFIGURATION SETTINGS

91Ti SETTINGS

SETTING	FACTORY DEFAULT	DESCRIPTION
LANGUAGE	ENGLISH	The language of the MESSAGE CENTER display. Choices include Portugese, Spanish, Dutch, Japanese, Italian, French, and German.
ENGLISH/METRIC UNITS	ENGLISH	The measurement unit type for weight, distance, and speed.
MAXIMUM SPEED	10 MPH (16.1 KPH)	This is the fastest speed at which the treadmill can run. The value can range between the minimum speed value and 10 MPH.
MINIMUM SPEED	0.5 MPH (0.8 KPH)	This is the slowest speed at which the treadmill can run. The value can range between .5 MPH and the maximum speed value.
MAXIMUM INCLINE	15.0	This option changes the maximum incline grade to a value lower than 15 percent.
MAXIMUM DURATION	60	This is the longest possible duration for which a workout can be set up. The range is 1 to 99.
TELEMETRY	ON	Switching on the telemetry feature makes it possible to use the Polar heart rate chest strap for monitoring the heart rate.
PAUSE TIMEOUT	1 (minute)	This is the maximum time during which a workout can remain in pause mode.
WATTS DISPLAY	OFF (Int'l: ON)	If this option is enabled, the MESSAGE CENTER displays the Watts equivalent of the step rate.
METS DISPLAY	OFF	If this option is enabled, the MESSAGE CENTER displays the METs equivalent of the step rate.
PACE DISPLAY	ON	This feature displays the rate of minutes per mile
CALORIE PER HOUR DISPLAY	ON (Int'l: OFF)	If this option is enabled, the MESSAGE CENTER displays the number of calories burned per hour during the workout.
DISTANCE CLIMBED DISPLAY	OFF	The total distance climbed, based on the incline and speed of the treadmill.
ACCELERATION RATE	3	The rate at which the treadmill speeds up to the selected speed, ranging from 1 (slowest) to 5 (fastest).
DECELERATION RATE	3	The rate at which the treadmill speeds up to the selected speed, ranging from 1 (slowest) to 5 (fastest).

[†] Defined by the American College of Sports Medicine's "Guidelines for Exercise Testing and Prescription" as equal to 220 minus an individual's age.

* Target Heart Rate (THR) is a percentage of the theoretical maximum (HRmax). For example, a 40-year-old user's recommended THR for the EXTREME HEART RATE™ WORKOUT is 153. The workout program targets a standard 85 percent of the maximum, so the equation would be $(220-40) \cdot .85 = 153$.

90T SETTINGS

Use the TIME/WEIGHT UP ARROW key to move forward through settings. Use the TIME/WEIGHT DOWN ARROW key to move backward through these settings. To change a setting, use the SPEED ARROW key. If display mode is turned off, each setting is identified as a numeral only.

FACTORY SETTING

FACTORY SETTING	DEFAULT	DESCRIPTION
DISPLAY MODE	"diSP ON" (1)*	This setting turns the console's ability to display messages on and off while in the Settings mode.
ENGLISH/METRIC UNITS	"UnitS LbS" (2)	The measurement unit type for weight, distance, and speed. "LbS" represents the ENGLISH system, and "grS" represents the Metric system.
MAXIMUM WORKOUT TIME	"tinE 99" (3)	This is the maximum allowable duration for a workout. The range is one to 99 minutes.
MAXIMUM SPEED	"SPd 10.0" (4)	This is the fastest speed at which the treadmill can run. The range is 0.5 MPH to 10 MPH (0.8 KPH to 16 KPH).
MAXIMUM INCLINE	"15.0" (5)	This is the maximum percentage to which the incline can be set. The range 0.0 percent to 15 percent.
FLYERS ON/OFF	"Fly ON"	(6) Flyers are the animated circles that appear in the DATA DISPLAY when the treadmill is turned on.
POLAR ON/OFF	"PoLAR ON" (7)	Switching on this feature makes it possible to use the Polar heart rate chest strap.
ACCELERATION RATE	"AccEL = 3" (8)	The rate at which the treadmill speeds up to the selected speed, ranging from 1 (slowest) to 5 (fastest).
DECELERATION RATE	"dEcEL = 3" (9)	The rate at which the treadmill speeds up to the selected speed, ranging from 1 (slowest) to 5 (fastest).
WAXER SYSTEM INSTALLED	"Lub SyS = no" (10)	This setting indicates whether or not a waxer system has been installed on the treadmill. This setting is changed when the wax bag is replaced on units with the factory-installed waxer option. See the topic titled Removing and Replacing the Wax Bag in Section 1.2 for more information.

**If display mode is turned off each setting is identified as a numeral only.*

6 SERVICE AND TECHNICAL DATA

6.1 PREVENTIVE MAINTENANCE TIPS

The Life Fitness treadmill is backed by the engineering excellence and reliability of Life Fitness and is one of the most rugged and trouble-free pieces of exercise equipment on the market today. Commercial Life Fitness treadmills are among the most popular of aerobic trainers, regularly standing up to marathon use - 18 hours a day, seven days a week - in health clubs, colleges and military facilities the world over.

NOTE: *Safety of the equipment can be maintained only if the equipment is examined regularly for damage or wear. Keep the equipment out of use until defective parts are repaired or replaced. Pay special attention to parts that are subject to wear, as outlined below.*

REMARQUE : *pour conserver un matériel sûr, il convient de l'inspecter régulièrement afin de déceler tout signe d'usure ou d'endommagement. N'utilisez pas l'appareil tant que les pièces défectueuses n'ont pas été réparées ou remplacées. Portez une attention toute particulière aux pièces qui s'usent, comme indiqué ci-dessous..*

The following preventive maintenance tips will keep the Life Fitness treadmill operating at peak performance:

- Clean the display console and all exterior surfaces regularly with mild soap and water or a mild household cleaner. DO NOT use paper towels, ammonia or acid based cleaners.*
- Check operation of the emergency stop system once a week.
- Check the operation of the stop button once a week.
- Inspect and vacuum the area under unit regularly.
- Vacuum around the striding belt regularly to keep debris from accumulating.
- Inspect exterior parts regularly for wear, particularly the striding belt and deck.
- Check the position (centering) of the striding belt.

The optimum operating position of the striding belt is from 1.5 inches (38 mm) to 2.0 inches (51 mm) from either side of the frame. If the striding belt travels beyond this position, see section 6.5, titled *How to Adjust and Tension the Striding Belt*, or contact Life Fitness Customer Support Services, for proper alignment instructions, 1-800-351-3737 (USA). See section 6.6, titled *How to Obtain Product Service* for customer support outside of the United States.

***NOTE:** *When cleaning the exterior of the unit, a non-abrasive cleaner and soft cotton cloth are strongly recommended. At no time should cleaner be applied directly to any part of the equipment; use non-abrasive cleaner on a soft cloth and then wipe the unit.*

6.2 PREVENTIVE MAINTENANCE SCHEDULE

Follow the schedule below to ensure proper operation of the product.

Follow the schedule below to ensure proper operation of the product.

ITEM	WEEKLY	MONTHLY	BI-ANNUALLY	ANNUALLY
Anti-Static Cords		I	R	
Console Mounting Bolts		I		
Frame	C			I
Striding Belt (Top)	C		I	
Deck	C (vacuum)		I	
Power Cord	I			
Display Console	C	I		
Accessory trays	C	I		
Handlebar	C		I	
Handrail Bolts			I	
Handlebar Bolts			I	
Front Roller			I	
Rear Roller			I	
Stop Key	I			
Rear Roller Guard		C and I		
Drive Motor Belt			I	
Wax Container		I		
Wax System Connections		I		
Wax Refill ¹	Per System Notification			

KEY: C=Clean; I=Inspect; R=Replace

6.3 TROUBLESHOOTING THE LIFEPULSE SYSTEM SENSORS

If the heart rate reading is erratic or missing, check the following:

- Dry moist hands to prevent slipping.
- Apply hands to all four sensors, two in each hand.
- Grasp the sensors firmly.
- Apply constant pressure around the sensors.
- Clean the sensors with a damp cloth.

6.4 TROUBLESHOOTING THE POLAR HEART RATE CHEST STRAP

HEART RATE IS ERRATIC OR ABSENT ENTIRELY

- Repeat the electrode wetting procedure. See Section 3.2, titled How to Use the Optional Heart Rate Monitor Chest Strap. The electrodes must be wet to pick up and transmit accurate heart rate readings.
- Make sure the electrodes are flat against the skin.
- Wash the belt transmitter regularly with mild soap and water.
- Make sure the chest strap transmitter is within three feet (one meter) of the heart rate receiver.
- The chest strap is battery operated and will eventually stop functioning. If the chest strap transmitter battery is depleted, contact Life Fitness Customer Support Services at **1-800-351-3737** for instructions on how to have the chest strap replaced.

HEART RATE READING IS ERRATIC OR EXTREMELY HIGH

When exercising with the optional heart rate chest strap, the user may come within range of electromagnetic signals strong enough to cause abnormally elevated heart rate readings.

POSSIBLE SOURCES OF SUCH SIGNALS INCLUDE

- Television sets and/or antennas, cell phones, computers, cars, high voltage power lines and motor driven exercise equipment.
- Another heart rate transmitter within three feet (one meter) may also cause abnormal heart rate readings.

6.5 REMOVING THE ACCESSORY TRAYS

The accessory trays should be removed and cleaned periodically. See section 6.2, titled *Preventive Maintenance Schedule*. To remove a tray, press inward the clip at the rear of the tray, and pull the tray out. To reinsert the tray, line up the notch in front with small slit and snap the top edge back into locked position.

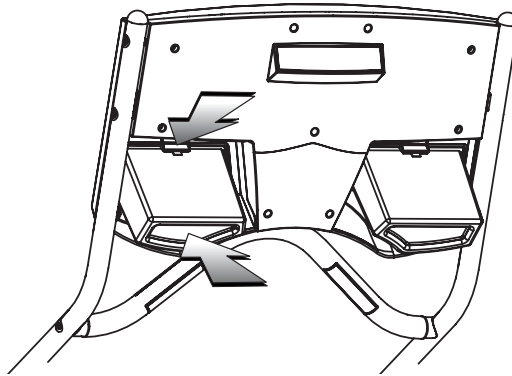

6.6 HOW TO ADJUST AND TENSION THE STRIDING BELT

Do not move the treadmill or place hands under treadmill while it is plugged into an electrical outlet!

THE BELT TENSIONING BOLTS

A 5/16-inch hex key wrench is required for this task. The Life Fitness treadmill has access holes in the rear roller guards which allow access to the tensioning bolts. These tensioning bolts make it possible to adjust the tracking and centering of the striding belt (A) without removing the guards.

NOTE: It is extremely important that the treadmill be correctly leveled prior to any tracking adjustments. An unstable unit may cause striding belt misalignment. See the topic titled *How To Stabilize the Life Fitness Treadmill in Section 1.2, titled Set Up*, prior to attempting any rear roller adjustments.

Before proceeding, it is helpful to visualize the REAR ROLLER (B) pivot point (C). Each adjustment made to one side of the ROLLER must be met with an equal and opposite adjustment (D) to the other side of the ROLLER to maintain an ideal belt tension at the pivot point.

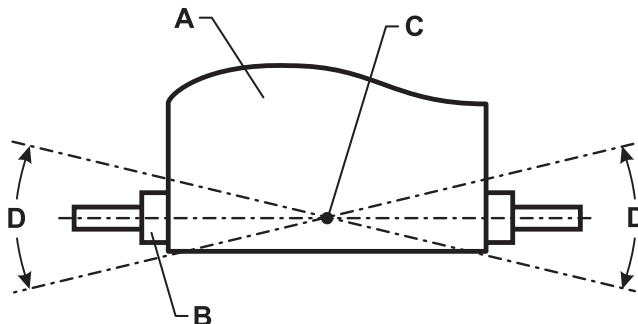

TRACKING (CENTERING) A STRIDING BELT

Two people are needed to perform this procedure.

- 1 Locate the two access holes to the belt tensioning bolts on each of the rear roller guards.
- 2 Stand on the sides of the treadmill and straddle the belt, not standing on it. Start a **MANUAL** workout, and set the belt speed to run at 4.0 mph (6,4 kph).
- 3 If the striding belt has moved to the right, turn the right tension bolt (B) $\frac{1}{4}$ turn clockwise with provided $\frac{1}{4}$ " Allen wrench, and then turn the left tension bolt (A) $\frac{1}{4}$ turn counter-clockwise to start striding belt tracking back to center of roller.

If the striding belt has moved to the left, turn the left tension bolt $\frac{1}{4}$ turn clockwise and then turn the right tension bolt $\frac{1}{4}$ turn counter-clockwise to start striding belt tracking back to center of roller. Repeat adjustments until striding belt appears centered. Allow machine to continue running for several minutes to observe if tracking remains stabilized.

NOTE: Do not exceed one full turn of the adjusting screws in either direction. If after one full turn the belt does not track properly, contact Customer Support Services. The phone numbers are listed in "How to Obtain Product Service."

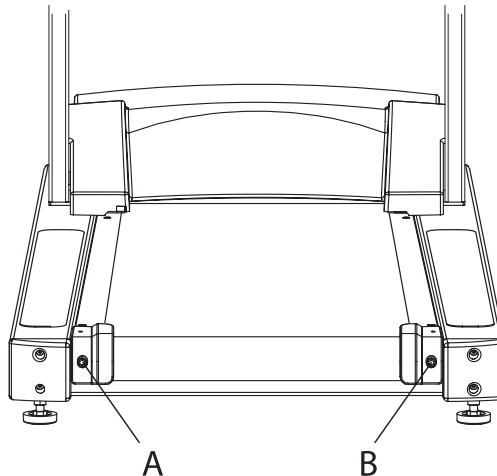

TENSIONING AN EXISTING STRIDING BELT

- 1 Enter the Manual workout and run the treadmill for five minutes at 5.0 MPH (8.0 KPH).
NOTE: DO NOT RUN ON BELT.
- 2 Reduce the speed to 2.0 MPH (3.2 KPH). Walk on the treadmill. Tightly grip the handrails and attempt to stall the striding belt. If the belt slips, continue to Step 3. If it does not slip, the tension is correct.
- 3 Using the STOP key, stop the treadmill. Turn the belt tensioning bolts a quarter-turn clockwise for each side. Do not exceed one full turn (four quarter turns) per side.
- 4 Enter the **MANUAL** workout and run the treadmill at 2.0 MPH (3.2 KPH) check to insure proper tracking. If the striding belt drifts to the left or right see the topic titled *Tracking (Centering) an Existing or New Striding Belt* on the previous page.

Do not over-tighten the tensioning bolts while making belt adjustments. Over-tightening of bolts may over stretch and damage the striding belt or roller bearings. Do not exceed one full turn of either bolt in either direction.

6.7 HOW TO OBTAIN PRODUCT SERVICE

1. Verify the symptom and review the operating instructions. The problem may be unfamiliarity with the product and its features and workouts.
2. Locate and write down the serial number of the unit, which is located on a plate near the power switch.
3. Contact Life Fitness Customer Support Services via the Web at: www.lifefitness.com, or call the nearest Life Fitness Customer Support Services group:

For Product Service within
the United States and Canada:

Telephone: (+1) 847.451.0036
FAX: (+1) 847.288.3702
Toll-free telephone: 800.351.3737

For Product Service Internationally:

Life Fitness Atlantic BV
Life Fitness Benelux
Bijdorplein 25-31
NL-2992 LB Barendrecht
Netherlands

Life Fitness Germany & Austria
Life Fitness Europe GmbH
Siemensstrasse 3
85716 Unterschleissheim
Germany

Life Fitness UKLTD
Queen Adelaide
Ely
Cambridgeshire
CB7 4UB

For Life Fitness Iberia (Spain)
C/Frederic Mompou 5
Edificio Euro 3
08960 Sant Just Desvern
(Barcelona) Spain

Life Fitness Italy
Centro Assistenza Tecnica ABS
Viale Kennedy 15/A
24066 Pedrengo
Brescia - IT

7 SPECIFICATIONS

7.1 LIFE FITNESS 91Ti TREADMILL SPECIFICATIONS

Designed use:	Standard duty
Maximum user weight:	350 pounds / 159 kilograms
Speed range:	0.5 - 10.0 MPH (0.8 - 16.1 KPH) in 0.1 increments
Elevation range:	0%-15% (in 0.5% increments)
Motor type:	DC
Motor size:	3.0 HP continuous duty
Power requirements:	120 volt, 20 amp (U.S.). See Electrical Requirements for requirements outside the United States.
Rollers:	2.75 inch (7 centimeter) diameter, steel precision crowned, front and rear
Striding belt:	60" Length x 20" Width (152 cm Length x 51 cm Width), multi-ply
Wax lubrication system:	Patented automatic wax lubrication system with the Everwax™ self-cleaning nozzle system, wax coated deck
Shock absorption system:	Patented FlexDeck® shock absorption system
Deck type:	3/4" medium density fiberboard, reversible
Front handrails:	Over-molded Ergo bar with Lifepulse system sensors; 1.625" (4.1 cm) diameter
Side handrails:	22" (56 cm) long, cantilevered
Stop systems:	Red Stop key and magnetic lanyard emergency stop system
Workouts:	Manual, Hill, Random, Fat Burn, Cardio
Levels:	20 (Hill and Random workouts)
Heart rate monitoring:	Lifepulse digital heart rate monitoring and Polar telemetry heart rate monitoring
Accessory tray:	Two standard, removable trays
Reading rack:	Standard, integrated in console
Console displays:	Time, distance, total calories burned, calories burned per hour, speed, incline, heart rate, pace, Watts, Mets, distance climbed
Communication port:	1 type RJ45, C-Safe-compatible; fitness network connection and fitness entertainment (power supply)

PHYSICAL DIMENSIONS

Length:	81 inches / 205.7 centimeters
Width:	32 inches / 81.3 centimeters
Height:	57.7 inches / 146.6 centimeters
Weight:	330 pounds / 149.7 kilograms

SHIPPING DIMENSIONS

Length:	85 inches / 216 centimeters
Width:	39 inches / 99 centimeters
Height:	19.5 inches / 49.5 centimeters
Weight:	372 pounds / 168.7 kilogram

7.2 LIFE FITNESS 90T TREADMILL SPECIFICATIONS

Designed use:	Standard duty
Maximum user weight:	350 pounds / 159 kilograms
Speed range:	0.5 - 10.0 MPH (0.8 - 16.1 KPH) in 0.1 increments
Elevation range:	0%-15% (in 0.5% increments) standard
Motor type:	DC
Motor size:	3.0 HP continuous duty
Power requirements:	120 volt, 20 amp (U.S.). See Electrical Requirements for requirements outside the United States.
Rollers:	2.75. (7 cm) diameter, steel, precision-crowned, front and rear
Striding belt:	60" Length x 20" Width (152 cm Length x 51 cm Width), multi-ply
Wax lubrication system:	Domestic: Pre-lubricated belt and wax coated deck; same as 9000 model when applicable International: Patented automatic wax lubrication system with the Everwax™ self-cleaning nozzle system, wax coated deck
Shock absorption system:	Patented FlexDeck® shock absorption system
Deck type:	3/4" medium density fiberboard, reversible
Front handrails:	Steel Ergo bar; 1.5" (3.8 cm) diameter
Side handrails:	22" (56 cm) long, cantilevered
Stop systems:	Red Stop key and magnetic lanyard emergency stop system
Workouts:	Quick Start/Manual
Heart rate monitoring:	Lifepulse digital heart rate monitoring and Polar telemetry heart rate monitoring
Accessory tray:	Two standard, removable trays
Reading rack:	Standard, integrated in console
Console displays:	Time, distance, calories, incline, speed, heart rate

PHYSICAL DIMENSIONS

Length:	81 inches / 205.7 centimeters
Width:	32 inches / 81.3 centimeters
Height:	57.7 inches / 146.6 centimeters
Weight:	330 pounds / 149.7 kilograms

SHIPPING DIMENSIONS

Length:	85 inches / 216 centimeters
Width:	39 inches / 99 centimeters
Height:	19.5 inches / 49.5 centimeters
Weight:	372 pounds / 168.7 kilogram