

***95R Recumbent Lifecycle[®]
Exercise Bike Base***

OPERATION MANUAL



LifeFitness

CORPORATE HEADQUARTERS

5100 River Road
Schiller Park, Illinois 60176 • U.S.A.
847.288.3300 • FAX: 847.288.3703
800.735.3867 (Toll-free within U.S.A., Canada)
Global Website: www.lifefitness.com

INTERNATIONAL OFFICES

AMERICA'S

North America Life Fitness Inc.

5100 N River Road
Schiller Park, IL 60176 U.S.A
Telephone: +1(847) 288 3300
Fax: +1(847) 288 3703
Service Email: internationalcustomersupport@lifefitness.com
Sales/Marketing Email: commercialsales@lifefitness.com
Operating Hours: 7:00 am-6:00 pm (CST)

Brazil Life Fitness Do Brazil

Av. Dr. Dib Sauaia Neto 1478
Alphaville, Barueri, SP
06465-140
BRAZIL
Telephone: (800) 773 8282
Fax: (+55) 11.4133.2893
Service Email: suporte@lifefitness.com.br
Sales/Marketing Email: lifefitness@lifefitness.com.br
Operating Hours: 8:30 am-17:30 pm (BRT)

Latin America & Caribbean* Life Fitness Inc.

5100 N River Road
Schiller Park, IL 60176 U.S.A
Telephone: +1(847) 288 3300
Fax: +1(847) 288 3703
Service Email: internationalcustomersupport@lifefitness.com
Sales/Marketing Email: commercialsales@lifefitness.com
Operating Hours: 8:00am-5:00pm (CST)

EUROPE, MIDDLE EAST, & AFRICA (EMEA)

Netherlands & Luxemburg Life Fitness Atlantic BV

Bijdorpplein 25-31
2992 LB Barendrecht
THE NETHERLANDS
Telephone: (+31) 180 646 666
Fax: (+31) 180 646 699
Service Email: service.benelux@lifefitness.com
Sales/Marketing Email: marketing.benelux@lifefitness.com
Operating Hours: 9.00h-17.00h (CET)

United Kingdom & Ireland Life Fitness UK LTD

Queen Adelaide
Ely, Cambs, CB7 4UB
Telephone: General Office (+44) 1353.666017 Customer
Support (+44) 1353.665507
Fax: (+44) 1353.666018
Service Email: uk.support@lifefitness.com
Sales/Marketing Email: life@lifefitness.com
Operating Hours:

General Office: 9.00am - 5.00pm (GMT)
Customer Support: 8.30am - 5.00pm (GMT)

Germany & Switzerland Life Fitness Europe GMBH

Siemensstrasse 3
85716 Unterschleissheim
GERMANY
Telephone: (+49) 89.31 77 51.0 (Germany)
(+41) 0848 000 901 (Switzerland)
Fax: (+49) 89.31 77 51.99 (Germany)
(+41) 043 818 07 20 (Switzerland)
Service Email: kundendienst@lifefitness.com
Sales/Marketing Email: kundenberatung@lifefitness.com
Operating Hours: 9.00h-17.00h (CET)

Austria Life Fitness Austria

Vertriebs G.m.b.H.
Dückerstrasse 7-9/3/36
1220 Vienna
AUSTRIA
Telephone: (+43) 1.61.57.198
Fax: (+43) 1.61.57.198.20
Service Email: kundendienst@lifefitness.com
Marketing/Sales Email: kundenberatung@lifefitness.com
Operating Hours: 9.00h-17.00h (CET)

Spain Life Fitness IBERIA

C/Frederic Mompou 5,1ª^a
08960 Sant Just Desvern Barcelona
SPAIN
Telephone: (+34) 936 724 660
Fax: (+34) 936 724 670
Service Email: info.iberia@lifefitness.com
Sales/Marketing Email: info.iberia@lifefitness.com
Operating Hours:
9.00h-18.00h (Monday-Thursday) (GMT)
8.30h-15.00h (Friday) (GMT)

Italy Life Fitness ITALIA S.R.L.

Via Crivellini 7/N
37010 Affi Verona
ITALY
Telephone: (+39) 045.7237811
Fax: (+39) 045.7238197
Service Email: assistenza@lifefitness.com
Sales/Marketing Email: info@lifefitnessitalia.com
Operating Hours: 8.30h -18.00h (CET)

Belgium Life Fitness Benelux NV

Parc Industriel de Petit-Rechain
4800 Verviers
BELGIUM
Telephone: (+32) 87 300 942
Fax: (+32) 87 300 943
Service Email: service.benelux@lifefitness.com
Sales/Marketing Email: marketing.benelux@lifefitness.com
Operating Hours: 9.00h -17.00h (CET)

All Other EMEA countries & distributor business C-EMEA*

Bijdorpplein 25-31
2992 LB Barendrecht
THE NETHERLANDS
Telephone: (+31) 180 646 666
Fax: (+31) 180 646 699
Service Email: service.db.cemea@lifefitness.com
Sales/Marketing Email: marketing.db.cemea@lifefitness.com
Operating Hours: 9.00h-17.00h (CET)

ASIA PACIFIC (AP)

Japan Life Fitness Japan

Nippon Brunswick Bldg., #8F
5-27-7 Sendagaya
Shibuya-Ku, Tokyo
JAPAN 151-0051
Telephone: (+81) 3.3359.4309
Fax: (+81) 3.3359.4307
Service Email:
service@lifefitnessjapan.com
Sales/Marketing Email
sales@lifefitnessjapan.com
Operating Hours: 9.00h-17.00h (GMT)

China and Hong Kong Life Fitness Asia Pacific LTD

Room 2610, Miramar Tower
132 Nathan Road
Tsimshatsui, Kowloon
HONG KONG
Telephone: (+852) 2891.6677
Fax: (+852) 2575.6001
Service Email: HongKongEnquiry@lifefitness.com
Sales/Marketing Email: ChinaEnquiry@lifefitness.com
Operating Hours: 9.00h-18.00h (GMT)

All Other Asia Pacific countries & distributor business Asia Pacific*

Room 2610, Miramar Tower
132 Nathan Road
Tsimshatsui, Kowloon
HONG KONG
Telephone: (+852) 2891.6677
Fax: (+852) 2575.6001
Service Email: HongKongEnquiry@lifefitness.com
Sales/Marketing Email: ChinaEnquiry@lifefitness.com
Operating Hours: 9.00h-18.00h (GMT)

* Also check www.lifefitness.com for local representation or distributor/dealer.

Before using this product, it is essential that this ENTIRE operation manual and ALL installation instructions be read.

This will help in setting up the equipment quickly and in instructing others on how to use it correctly and safely.

Avant toute utilisation de ce produit, il est indispensable de lire ce manuel d'utilisation dans son INTÉGRALITÉ, ainsi que TOUTES les instructions d'installations.

Ce manuel explique comment installer l'équipement et comment l'utiliser correctement et sans danger.

FCC Warning - Possible Radio / Television Interference

NOTE: *This equipment has been tested and found to comply with the limits for a Class A digital device, pursuant to part 15 of the FCC rules. These limits are designed to provide reasonable protection against harmful interference when the equipment is operated in a commercial environment. This equipment generates, uses and can radiate radio frequency energy, and if not installed and used in accordance with the operation manual, may cause harmful interference to radio communications. Operation of this equipment in a residential area is likely to cause harmful interference in which case the user will be required to correct the interference at his own expense.*

Class S (Studio): Professional and / or commercial use.



CAUTION: Any changes or modifications to this equipment could void the product warranty.



MISE EN GARDE: Tout changement et toute modification de ce matériel peut annuler la garantie du produit.

Any service, other than cleaning or user maintenance, must be performed by an authorized service representative. There are no user serviceable parts.

TABLE OF CONTENTS

Section	Description	Page
1.	Getting Started	5
1.1.	Important Safety Instructions	5
1.2.	Setup	7
	Electrical Power Requirements//Where to Place the Recumbent Lifecycle® Exercise Bike // How to Stabilize the Recumbent Lifecycle Exercise Bike//Check for Battery Power// Check for External Power// How to Adjust the Seat// How to Adjust the Pedal Straps	
2.	Service and Technical Data	10
2.1	Preventive Maintenance Tips	10
2.2	Preventive Maintenance Schedule	11
2.3	Troubleshooting the Polar® Heart Rate Chest Strap	11
	Heart Rate Reading is Erratic, Absent Entirely, or Abnormally Elevated	
2.4	Troubleshooting the Lifepulse™ System Sensors	12
2.5	Recycling the Battery	12
2.6	How to Obtain Product Service	12
3	Specifications	12
3.1	95R Recumbent Lifecycle Exercise Bike Base	13

© 2008 Life Fitness, a division of Brunswick Corporation. All rights reserved. Life Fitness, a division of Brunswick Corporation. All rights reserved. Life Fitness, Heart Rate Zone Training, and Lifepulse are registered trademarks of Brunswick Corporation. Fit Stride, Heart Rate Zone Training+, Heart Rate Hill, Heart Rate Interval, and Extreme Heart Rate are trademarks of Brunswick Corporation. Polar is a registered trademark of Polar Electro, Inc. Cardio Theater is a registered trademark of the Cardio Theater Holdings. FitLinxx is a registered trademark of the Integrated Fitness Corp. Any use of these trademarks, without the express written consent of Life Fitness or the corresponding companies is forbidden.

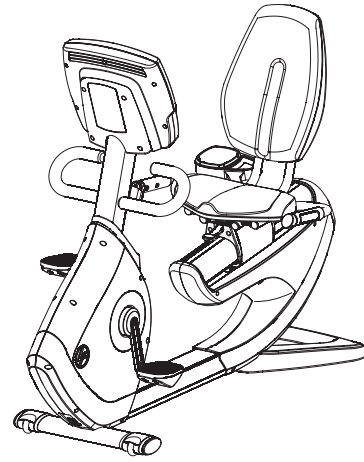
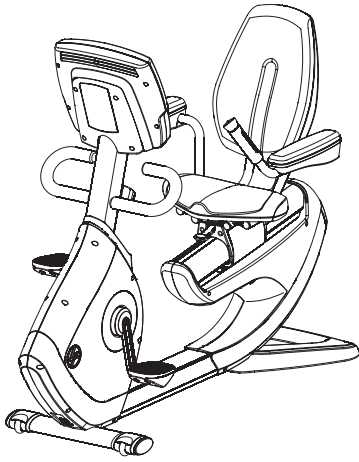

This Operation Manual describes the functions of the following product:
Life Fitness Recumbent Lifecycle Exercise Bike:

95R

See "Specifications" page in this manual for product specific features.

Statement of Purpose: The Life Fitness Recumbent Lifecycle Exercise Bike is a speed-independent machine that simulates the movements of riding a bicycle at various speeds and levels of resistance.

 **CAUTION: Health-related injuries may result from incorrect or excessive use of exercise equipment. Life Fitness STRONGLY recommends seeing a physician for a complete medical exam before undertaking an exercise program, particularly if the user has a family history of high blood pressure or heart disease, or is over the age of 45, or smokes, has high cholesterol, is obese, or has not exercised regularly in the past year.**

If, at any time while exercising, the user experiences faintness, dizziness, pain, or shortness of breath, he or she must stop immediately.

 **MISE EN GARDE: Des problèmes de santé peuvent être causés par une utilisation incorrecte ou excessive de l'équipement. Life Fitness conseille VIVEMENT de consulter un médecin pour subir un examen médical complet avant de commencer tout programme d'exercice, et tout particulièrement si l'utilisateur a des antécédents familiaux d'hypertension ou de troubles cardiaques, ou s'il a plus de 45 ans, s'il fume, s'il a du cholestérol, s'il est obèse ou n'a pas fait d'exercice régulièrement depuis un an.**

Si, pendant l'utilisation de l'appareil, l'utilisateur ressent un malaise, des vertiges, des douleurs ou des difficultés à respirer, il doit cesser immédiatement.

1 GETTING STARTED

1.1 IMPORTANT SAFETY INSTRUCTIONS



SAFETY WARNING: The safety of the product can be maintained only if it is examined regularly for damage and wear. See Preventive Maintenance section for details.

- If this Life Fitness product does not function properly after it has been dropped, damaged, or even partially immersed in water, contact Life Fitness Customer Support Services for assistance.
- Always follow the console instructions for proper operation.
- Close supervision is necessary when used by children, invalids or disabled persons.
- Do not use this product outdoors, near swimming pools or in areas of high humidity.
- Never operate a Life Fitness product with the air openings blocked. Keep air openings free of lint, hair or any obstructing material.
- Never insert objects into any opening in this product. If an object should drop inside, carefully retrieve it. If the item cannot be reached, contact Life Fitness Customer Support Services.
- Never place liquids of any type directly on the unit, except in the accessory tray water bottle holder. Containers with lids are recommended.
- Wear shoes with rubber or high-traction soles. Do not use shoes with heels, leather soles, cleats or spikes. Make sure no stones are embedded in the soles.
- Keep all loose clothing, shoelaces and towels away from moving parts.
- Do not use this product in bare feet.
- Do not tip the unit on its side during operation.
- Keep the area around the Recumbent Lifecycle Exercise Bike clear of any obstructions, including walls and furniture. Ensure that there is at least three feet of clearance behind the Recumbent Lifecycle Exercise Bike.
- Use caution when mounting or dismounting the Recumbent Lifecycle Exercise Bike. Use the stationary handlebar whenever additional stability is required.
- Never use the Recumbent Lifecycle Exercise Bike while facing backward.

SAVE THESE INSTRUCTIONS FOR FUTURE REFERENCE.

1 POINT DE DÉPART

1.1 CONSIGNES DE SÉCURITÉ IMPORTANTES

 **CONSIGNE DE SÉCURITÉ :** pour un emploi sûr, le produit doit être inspecté régulièrement afin de s'assurer qu'il n'est pas usé ni endommagé. Consultez la section de Maintenance préventive pour obtenir de plus amples informations.

- Si l'appareil Life Fitness ne fonctionne pas correctement après avoir subi une chute, des dommages ou une immersion même partielle dans l'eau, contactez le service d'assistance clientèle de Life Fitness.
- Pour un fonctionnement correct, suivez toujours les instructions de la console.
- Une surveillance étroite est nécessaire en cas d'utilisation par des enfants, des personnes invalides ou handicapées.
- N'utilisez pas ce produit à l'extérieur, près d'une piscine ou dans endroits très humides.
- Ne faites jamais fonctionner de produit Life Fitness dont les bouches d'aération seraient bloquées. Maintenez-les exemptes de peluches, de cheveux ou de toute obstruction.
- N'insérez jamais d'objet dans les ouvertures de cet appareil. Si un objet tombe dedans, coupez l'alimentation électrique, débranchez le cordon de la prise et récupérez-le avec précaution. Si vous ne pouvez pas l'atteindre, consultez le service après-vente de Life Fitness.
- Ne placez jamais de liquides d'aucune sorte directement sur l'appareil, sauf si vous disposez d'un support ou d'un plateau pour accessoires. Il est recommandé d'utiliser des conteneurs munis d'un couvercle.
- Portez des chaussures avec semelles en caoutchouc ou antidérapantes. N'utilisez pas de chaussures à talons, de semelles en cuir ou à crampons. Assurez-vous qu'aucun caillou ne s'est incrusté dans les semelles.
- Maintenez les vêtements lâches, les lacets et les serviettes à l'écart des pièces en mouvement.
- N'utilisez pas cet appareil sans chaussures.
- Ne faites pas basculer l'appareil sur le côté tandis qu'il fonctionne.
- Maintenez la zone autour du produit Life Fitness exempte d'obstructions, y compris de murs et de meubles. Veillez à laisser au moins 91.4 cm d'espace derrière du Life Fitness Recumbent Lifecycle Exercise Bike.
- Procédez avec précaution lors du montage ou du démontage de la machine. Utilisez la barre fixe pour renforcer votre stabilité.
- N'utilisez jamais cet appareil en vous tournant vers l'arrière.

CONSERVEZ CES INSTRUCTIONS POUR USAGE ULTÉRIEUR.

1.2 SETUP

Read the Operation Manual before setting up the Recumbent Lifecycle[®] Exercise Bike.

ELECTRICAL POWER REQUIREMENTS

The Recumbent Lifecycle Exercise Bike with the Engage Console (15" LCD) requires an AC power supply according to the electrical configurations listed in the chart below. External power is optional with the Inspire Console (7" LCD) and the Achieve Console (LED).

Supply Voltage (VAC)	Frequency (Hz)	Rated Current (Amps)
100	50 / 60	1.6
110	50 / 60	1.6
120	50 / 60	1.6
200	50 / 60	.8
220	50 / 60	.8
230	50 / 60	.8
240	50 / 60	.8

NOTE: Do not modify the plug provided with this product. If the plug does not fit into an available electrical outlet, have a proper outlet installed by a qualified electrician.

WHERE TO PLACE THE RECUMBENT LIFECYCLE EXERCISE BIKE

Following all safety instructions in Section 1.1, move the bike to the location in which it will be used. See Section 3, titled *Specifications*, for the dimensions of the product footprint (assembled dimensions). Allow a distance of 8 to 12 inches, or 21 to 30 centimeters, between the bike and other objects or surfaces on either side. Allow a distance of 3 feet, or 1 meter, from the front or rear of the bike to any other object or surface.

HOW TO STABILIZE THE RECUMBENT LIFECYCLE EXERCISE BIKE

After placing the bike in position, check the unit's stability by attempting to rock it from side to side. Any slight rocking indicates that the unit must be leveled. Determine which foot is not resting completely on the floor. Loosen the jam nut (A) with an open-end M17 wrench, and rotate the stabilizing foot (B) to lower it. Verify that the bike is stable, and repeat the adjustment as necessary until the unit no longer rocks. Lock the adjustment by tightening the jam nut against the stabilizer bar.

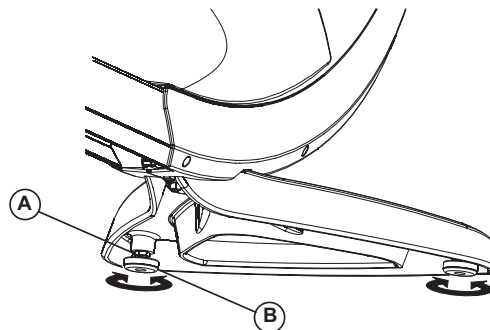

CHECK FOR BATTERY POWER

The Achieve (LED) and Inspire (7" LCD) consoles are powered by a rechargeable 6-volt battery. Check the battery by pressing and holding the power on/off  key. The console should beep and light up. The Message Center on the Achieve console will display a prompt to set up a workout. The Inspire console will show a message on the LCD indicating it is initializing (for up to 2 minutes). If a prompt doesn't appear or initializing doesn't begin, mount the Recumbent Lifecycle Exercise Bike and begin pedaling. The console should light up and programming a workout should be possible. Pedal for 20 minutes at 40 rpm or faster during a workout to charge the battery. The pedal action during workouts keeps the battery charged. If the Lifecycle Exercise Bike is externally powered by the 36V DC power supply, battery maintenance is automatic and pedaling is not required.

1.2 SETUP

CHECK FOR EXTERNAL POWER

The Engage (15" LCD) console is powered by an external AC-DC 36-volt power supply. Make sure to plug **the external power connector to the front of the Recumbent Lifecycle Bike before plugging the AC power in**. Plug the AC Input cord into an AC outlet. The console should immediately beep and light up. The Engage console will show a message indicating it is initializing (for up to 2 minutes).

NOTE: If any of the consoles do not light up, contact Life Fitness Customer Service (*refer to page one of the manual*).

The following connection receptacles are located at the front of the Recumbent Lifecycle Exercise Bike: Attachable TV power (C), coaxial cable (D), external power for the Engage console or optional external power (E), and fitness networking (F).



CAUTION: Connectors should easily fit into the receptacles. Forcing a connection may lead to damage to the barrel connector and/or receptacle and may void product warranty.

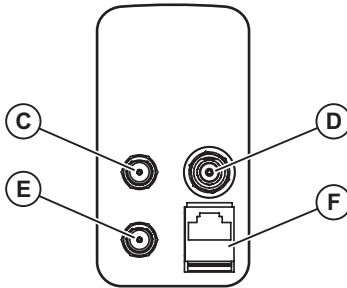

HOW TO ADJUST THE SEAT

A properly adjusted seat is extremely important in any bike-oriented exercise activity and the Recumbent Lifecycle Exercise Bike is no exception. If the seat is too close, excessive strain will be placed on the knees and quadriceps muscles; if the seat is too far, the resulting reaching action will irritate the feet, ankles, hips and knees.

Sit on the seat and place the balls of the feet on the pedals. An optimum position will allow movement through the bottom of the stroke without locking the knees or shifting in the seat. The knees should have a slight bend at the point of fullest leg extension.

If the seat needs to be adjusted, lift the spring-loaded adjusting handle (G) located underneath the nose of the seat. Hold both the handle and nose of the seat with one hand and use the other hand to grab the rear of the seat. Slide the handle and seat forward or backward as necessary to the proper position. Release the pin to complete engagement. Gently slide the seat forward and backward a small distance to ensure it is locked into place. Check the seat distance again and re-adjust it if necessary.

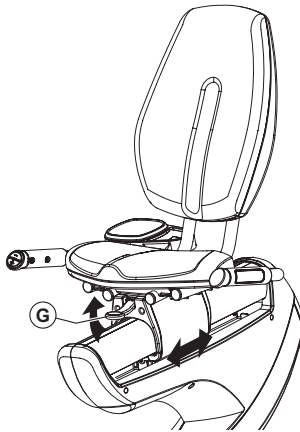

CAUTION: Do not attempt to adjust the seat while pedaling the bike. Doing so may result in an uncomfortable workout or cause injury.



MISE EN GARDE : N'essayez pas de régler la place en cyclisme la bicyclette. L'action peut ainsi s'ensuivre dans une séance de mise en forme inconfortable ou provoquer la blessure.

1.2 SETUP

HOW TO ADJUST THE PEDAL STRAPS

The bike pedal straps keep the user's shoes on the pedals during a workout. The straps should fit comfortably, but they also should be tight enough to prevent shoes from slipping at any point in the pedaling rotation. Before working out, a user should test and adjust the tightness of the straps.

The safety straps on the foot pedals of the Recumbent Lifecycle Exercise Bike can be adjusted to fit a variety of shoe sizes. Use one hand to push the strap latch (H) upward to loosen the ribbed strap (I). Use the other hand to pull the ribbed strap out from underneath the strap latch. Rest the foot on the pedal (J). Wrap the ribbed strap over the foot to determine the desired length. Push the strap latch upward and thread the ribbed strap through the strap latch to select the appropriate slot. Let go of the strap latch to secure position.

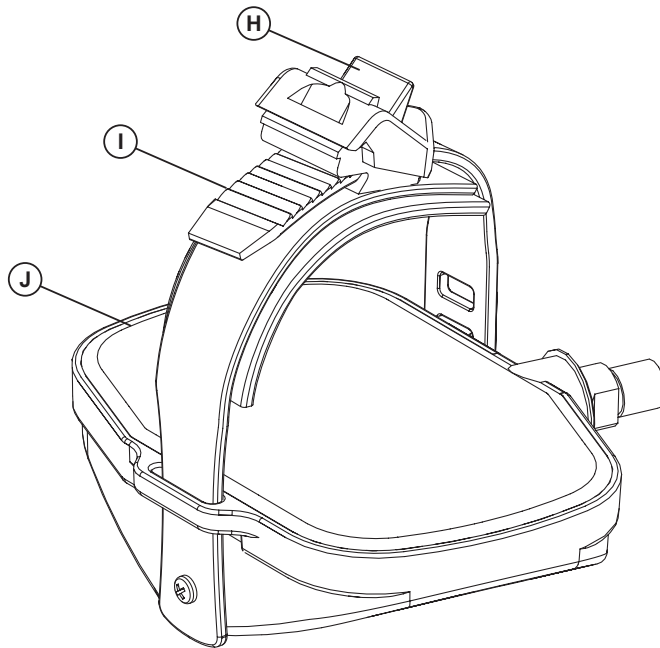

2 SERVICE AND TECHNICAL DATA

2.1 PREVENTIVE MAINTENANCE TIPS

The Recumbent Lifecycle Exercise Bike is backed by the engineering excellence of Life Fitness and is one of the most rugged and trouble-free pieces of exercise equipment on the market today. Commercial Life Fitness products have proven to be durable in health clubs, colleges, and military facilities the world over. This same technology, engineering expertise, and reliability have gone into the Recumbent Lifecycle Exercise Bike.

NOTE: *The safety of the equipment can be maintained only if the equipment is examined regularly for damage or wear. Keep the equipment out of use until defective parts are repaired or replaced. Pay special attention to parts that are subject to wear as outlined in the Preventive Maintenance Schedule.*

REMARQUE : *pour conserver un matériel sûr, il convient de l'inspecter régulièrement afin de déceler tout signe d'usure ou d'endommagement. N'utilisez pas l'appareil tant que les pièces défectueuses n'ont pas été réparées ou remplacées. Portez une attention toute particulière aux pièces qui s'usent, comme indiqué ci-dessous.*

The following preventive maintenance tips will keep your Recumbent Lifecycle Exercise Bike operating at peak performance:

- Locate the Recumbent Lifecycle Exercise Bike in a cool, dry place.
- Keep the pedal straps fastened securely when using the bike.
- Clean the top surface of the pedals regularly.
- Use a 100% cotton cloth, lightly moistened with water and mild liquid detergent, to clean the Recumbent Lifecycle Exercise Bike. Other fabrics, including paper towels, may scratch the surface. Do not use ammonia, chlorine, or acid-based cleaners.
- Clean the frame thoroughly on a regular basis.



NOTE: When cleaning the exterior of the unit, a non-abrasive cleaner and soft cotton cloth are strongly recommended. At no time should cleaner be applied directly to any part of the equipment; apply the non-abrasive cleaner on a soft cloth and then wipe the unit.

2.2 PREVENTIVE MAINTENANCE SCHEDULE

Follow the schedule below to ensure proper operation of the product.

<i>ITEM</i>	<i>WEEKLY</i>	<i>MONTHLY</i>	<i>BI-ANNUALLY</i>	<i>ANNUALLY</i>
<i>Frame/Seat Post</i>	<i>Clean</i>			<i>Inspect</i>
<i>Pedals/Straps</i>	<i>Clean</i>	<i>Inspect</i>		
<i>Accessory Tray</i>	<i>Clean</i>	<i>Inspect</i>		
<i>Plastic Covers</i>	<i>Clean</i>	<i>Inspect</i>		

2.3 TROUBLESHOOTING THE POLAR® HEART RATE CHEST STRAP

HEART RATE READING IS ERRATIC, ABSENT ENTIRELY, OR ABNORMALLY ELEVATED

Malfunction	Probable Cause	Corrective Action
Heart rate reading is erratic or absent entirely	Belt transmitter electrodes are not wet enough to pick up accurate heart rate readings.	Wet the belt transmitter electrodes.
	Belt transmitter electrodes are not laying flat against the skin.	Ensure the belt transmitter electrodes are laying flat against the skin.
	Belt transmitter needs cleaning.	Wash the belt transmitter with mild soap and water.
	Belt transmitter is not within 3 feet (one meter) of the heart rate receiver.	Make sure the chest strap transmitter is within three feet (one meter) of the heart rate receiver.
	Chest strap battery is depleted.	Contact Life Fitness Customer Support Services for instructions on how to have the chest strap replaced.
Abnormally elevated heart rate readings	Electromagnetic interference from television sets and/or antennas.	Move the exercise equipment a few inches away from the probable cause, or move the probable cause a few inches away from the exercise equipment, until the heart rate readings are accurate.
	Electromagnetic interference from cell phones.	
	Electromagnetic interference from computers.	
	Electromagnetic interference from cars.	
	Electromagnetic interference from high voltage power lines.	
	Electromagnetic interference from motor driven exercise equipment.	
	Electromagnetic interference from another heart rate transmitter within three feet (one meter).	

2.4 TROUBLESHOOTING THE LIFEPULSE SYSTEM SENSORS

If the heart rate reading is erratic or missing, do the following:

- Dry the hands if necessary to prevent slipping.
- Apply hands to the sensors that are set into the side handlebars or armrests.
- Grasp the sensors firmly.
- Apply constant pressure around the sensors.

2.5 RECYCLING THE BATTERY

When this Life Fitness product is about to be discarded at the end of its useful life, the rechargeable battery must be removed and recycled. To access the battery, use a medium tip Phillips screw driver to remove the two screws that hold the end cap shroud to the back of the bike. To remove the battery, remove the two wires connected to the battery and the two screws that hold the battery in place. Dispose of the battery properly.

2.6 HOW TO OBTAIN PRODUCT SERVICE

1. Verify the symptom and review the operating instructions. The problem may be unfamiliarity with the product and its features and workouts.
2. Locate the serial number plate, which is located on the front stabilizer. Document the serial number, which consists of three letters followed by six numerals.
3. Contact Life Fitness Customer Support Services via the Web at www.lifefitness.com, or call the nearest Life Fitness Customer Support Services group (*refer to page 1 of this manual*).

3 SPECIFICATIONS

3.1 95R RECUMBENT LIFECYCLE EXERCISE BIKE BASE

Designed use:	Heavy/Commercial
Maximum user weight:	400 pounds / 181.44 kilograms
Power requirements:	See Electrical Requirements on page 7 for use with the Engage Console. External power is optional with the Inspire and Achieve Consoles.
Pedal size:	6.56 inches x 5.5 inches / 166.6 millimeters x 140.9 millimeters
Pedal speed range:	40 RPM - 120 RPM
Drive type:	Alternator/Belt
Accessory Tray:	Standard
Integrated Reading Rack:	Standard
Color:	Silver with gray accents

PHYSICAL DIMENSIONS:

Length:	63 inches / 160 centimeters
Width:	26.75 inches / 68 centimeters
Height:	51.75 inches / 131 centimeters
Weight:	187 pounds / 85 kilograms

SHIPPING DIMENSIONS:

Length:	69 inches / 175 centimeters
Width:	24.75 inches / 65 centimeters
Height:	45 inches / 114 centimeters
Weight:	235 pounds / 107 kilograms

