

MATRIX

1-SERIES

R1x Recumbent Bike

U1x Upright Bike

TABLE OF CONTENTS

		PAGE #
CHAPTER 1: IMPORTANT SAFETY INSTRUCTIONS		
1.1	Before Getting Started	02
1.2	Proper Usage	02
1.3	Read and Save These Instructions	02
CHAPTER 2: SETUP		
2.1	Getting Started	03
2.2	Choosing a Location	03
2.3	Stabilizing the Bike	03
2.4	Adjusting the Pedal Strap	03
2.5	Adjusting the Seat	04
2.6	Self Powered Features.....	04
2.7	Unpacking the Bikes.....	05
CHAPTER 3: SERIAL NUMBER LOCATION		
3.1	R1x Recumbent	07
3.1	U1x Upright	07
CHAPTER 4: BIKE PARTS & ASSEMBLY GUIDES		
4.1	Fasteners U1x	08
4.2	Exploded Diagram U1x	09
4.3	Assembly Steps U1x	10
4.4	Fasteners R1x	13
4.5	Exploded Diagram R1x	14
4.6	Assembly Steps R1x	15
CHAPTER 5: OVERLAY DESCRIPTION / ENGINEERING MODE		
5.1	Console Display	19
5.2	Workout Parameter Prompts	20
5.3	Workout Overviews	21
5.4	Workout Tips	23
5.5	Workout Setup Steps	26
5.6	Using Fitness Networking	26
CHAPTER 6: MANAGER'S CUSTOM MODE		
6.1	List of Manager's Custom Mode	27
CHAPTER 7: MAINTENANCE		
7.1	Daily Inspection	29
7.2	Daily Maintenance	29
7.3	Monthly Maintenance	29
7.4	Recycling the Battery	29
CHAPTER 8: Product Specifications		30

CHAPTER 1: IMPORTANT SAFETY INSTRUCTIONS

1.1 BEFORE GETTING STARTED

It is the sole responsibility of the purchaser of Matrix Fitness Systems products to instruct all individuals, whether they are the end user or supervising personnel, on proper usage of the equipment.

It is recommended that all users of Matrix Fitness Systems exercise equipment be informed of the following information prior to its use.

1.2 PROPER USAGE

- Do not use the equipment in any way other than designed or intended by the manufacturer. It is imperative that all Matrix Fitness Systems equipment is used properly to avoid injury.
- Keep hands and feet clear of moving parts at all times to avoid injury.
- Unsupervised children must be kept away from this equipment.
- Do not wear loose clothing while on equipment.

1.3 READ AND SAVE THESE INSTRUCTIONS

This bike is intended for commercial use. To ensure your safety and protect the equipment, read all instructions before operating the Matrix bike.

- Use the bike for its intended purpose as described in this manual. Do not use attachments that have not been recommended by the manufacturer.
- Never drop or insert any object into any opening of the product. If an object drops inside, carefully retrieve it while the unit is not in use. If the item cannot be reached, contact Matrix Fitness or the authorized dealers.
- Never operate the bike if it is not working properly, or if it has been damaged or immersed in water. Return the bike to Matrix Fitness or the authorized dealers for examination and repair.
- Keep hands and feet clear at all times from moving parts to avoid injury.
- Do not reach into, or underneath the unit, and do not tip the unit on its side during operation.
- Do not use the Matrix bikes outside, near swimming pools or in areas of high humidity.
- Do not operate where aerosol (spray) products are being used or when oxygen is being administered.
- Do not use this product in bare feet. Do not wear shoes with heels, leather soles, cleats or spikes while exercising.

- Do not remove the side covers. Service should only be done by an authorized service technician.
- Close supervision is necessary when used near children, invalids or disabled people.
- When the bike is in use, young children and pets should be kept at least three meters / ten feet away.
- Assemble and operate the unit on a solid, level surface. Locate the unit at least one meter / three feet of clearance from any obstructions, including walls and furniture.
- Never face backward while using the Matrix bike.
- Use the stationary handlebars to mount or dismount the bike.
- Do not wear any clothing that might catch on any moving parts of this bike.

CAUTION: If you experience chest pain, nausea, dizziness or shortness of breath, STOP exercising immediately and consult a physician before continuing.

CAUTION: Any changes or modifications to this equipment could void the product warranty.

CHAPTER 2: SETUP

2.1 GETTING STARTED

Read the Owner's Manual before setting up the Matrix bike. Place the unit where it will be used before beginning the setup procedure.

2.2 CHOOSING A LOCATION

The site should be well-lit and well-ventilated. Place the bike on a structurally solid flat surface and kept a few feet from the wall or any equipment. If the site has a heavy plush carpet, to protect the carpeting and machinery, you should place a rigid plastic base under the unit.

Please do not place the bike in an area of high humidity, such as the vicinity of a steam room, indoor pool, or sauna. Exposure to intensive water vapour or chlorine could adversely affect the electronics, as well as other parts of the machine. To make exercise a desirable daily activity for you, these two bikes should be in an attractive setting.

2.3 STABILIZING THE BIKE

After positioning the bike in its intended location, check its stability by attempting to shake it side to side. Shaking or wobbling indicates that your bike needs to be leveled. Determine which leveler is not resting completely on the floor. Loosen the nut with one hand to allow the leveler to rotate. Rotate the left or right leveler, and repeat the adjustment as necessary until the bike is stable. Lock the adjustment by tightening the nut against the rear foot support.

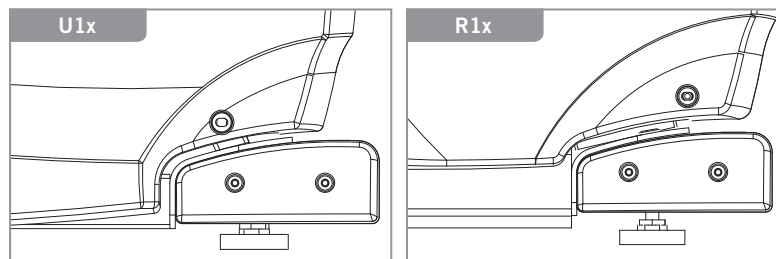

2.4 ADJUSTING THE PEDAL STRAP

The straps are designed to fit your individual foot size and should be adjusted tight enough to keep your feet from slipping. The pedals include spring-loaded clips for easy adjustment. To tighten the strap, pull down the open end of the strap. To loosen the strap, push down on the top of the clip and pull the strap up. Release the clip to lock in place.



CHAPTER 2: Setup

2.5 ADJUSTING THE SEAT

RECUMBENT BIKE R1x

While seated on the R1x, an optimum position will allow movement through the bottom of the stroke without locking the knees or shifting in the seat. The knees should have a slight bend at the point of fullest leg extension.

If the seat needs to be adjusted, lift the spring-loaded seat lever on the right side of the seat to make adjustments. Slide the seat forward or backward to desired location. Release the spring-loaded seat lever and gently attempt to rock forward and backward to assure it is locked in place. Check the seat distance again and re-adjust it if necessary.

UPRIGHT BIKE U1x

To determine whether or not the seat requires adjustment, sit on it and place the foot ankle on the pedals. The knee should bend slightly when the pedal is at the lowest point of its rotation. It should be possible to pedal without locking the knees or shifting in the seat. The U1x features a vertical ratchet seat adjustment system, which makes it easy and safe to change the height of the seat quickly.

To raise the seat, pull the seat upward to the desired height, and let it lock in place. Test and re-adjust the seat height as necessary.

To lower the seat, first get off the bike. Holding the seat, pull out the seat post knob. Let the seat slide down to the desired height and release the seat post knob. Test and re-adjust the seat height as necessary.

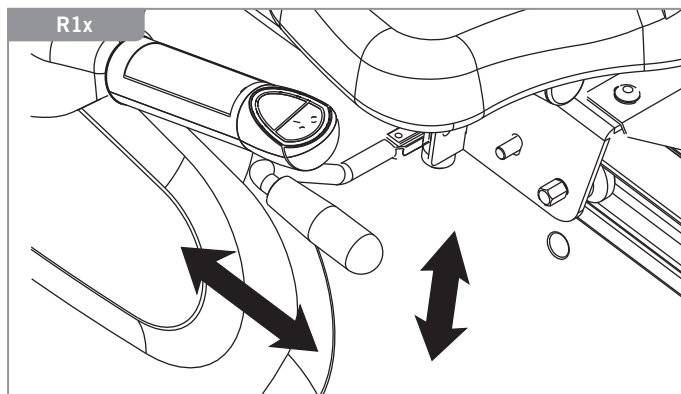
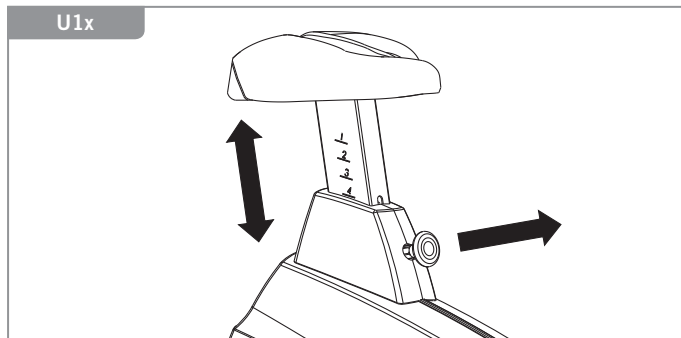

2.6 SELF POWERED FEATURES

On the bikes, the user's pedaling generates the power to initialize and display information on the monitor. A minimum of 30 RPM (revolutions per minute) is required to start and maintain enough power to keep the monitor functional. If the minimum RPM is not maintained, the monitor will begin to shutdown. The U1x and R1x are able to extend time to display the monitor, at the minimum RPM not maintained, if the bikes are equipped with the battery. The bike saves its battery charge by moving into a shutdown mode whenever PEDAL FASTER appears on the display.

NOTE: The battery is not equipped with the bike for a standard specification.

If your bike equipped with the battery receives inconsistent use, or long time periods between use, the battery may require recharging. The adapter is an optional accessory for recharging the unit. To purchase the optional battery and adapter please contact Matrix Fitness or your local dealer.

SYMPTOMS OF A LOW BATTERY

If the bike has not been used for an extended period of time, the battery may require recharging. Symptoms of a low battery can include:

- A "LOW BATTERY" message will appear on the monitor
- Backlighting on the LCD display will be disabled
- No one uses the bike for an extended period of time.

If the battery must be recharged, use the optional power adapter charging unit. The charger should be connected to the bike for a minimum of eight hours to ensure a thorough charge. If LOW BATTERY still appears on the display after full charging, the battery could be extinct. Please check with an authorized service technician for replacing the battery.

REPLACING THE BATTERY

The unit's battery is built to last for a long time. However, if you feel that the battery may need replacing, check with an authorized service technician.

CAUTION: The battery stored inside the unit contains hazardous materials to the environment. Proper disposal of the battery is required by the law.

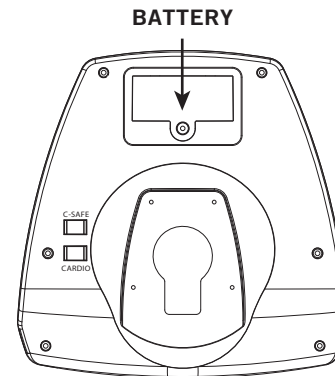

CHAPTER 2: Setup

2.7 UNPACKING THE BIKES

The bike is carefully inspected before shipment so it should arrive in good operating condition. Matrix Fitness ships the unit in the following pieces:

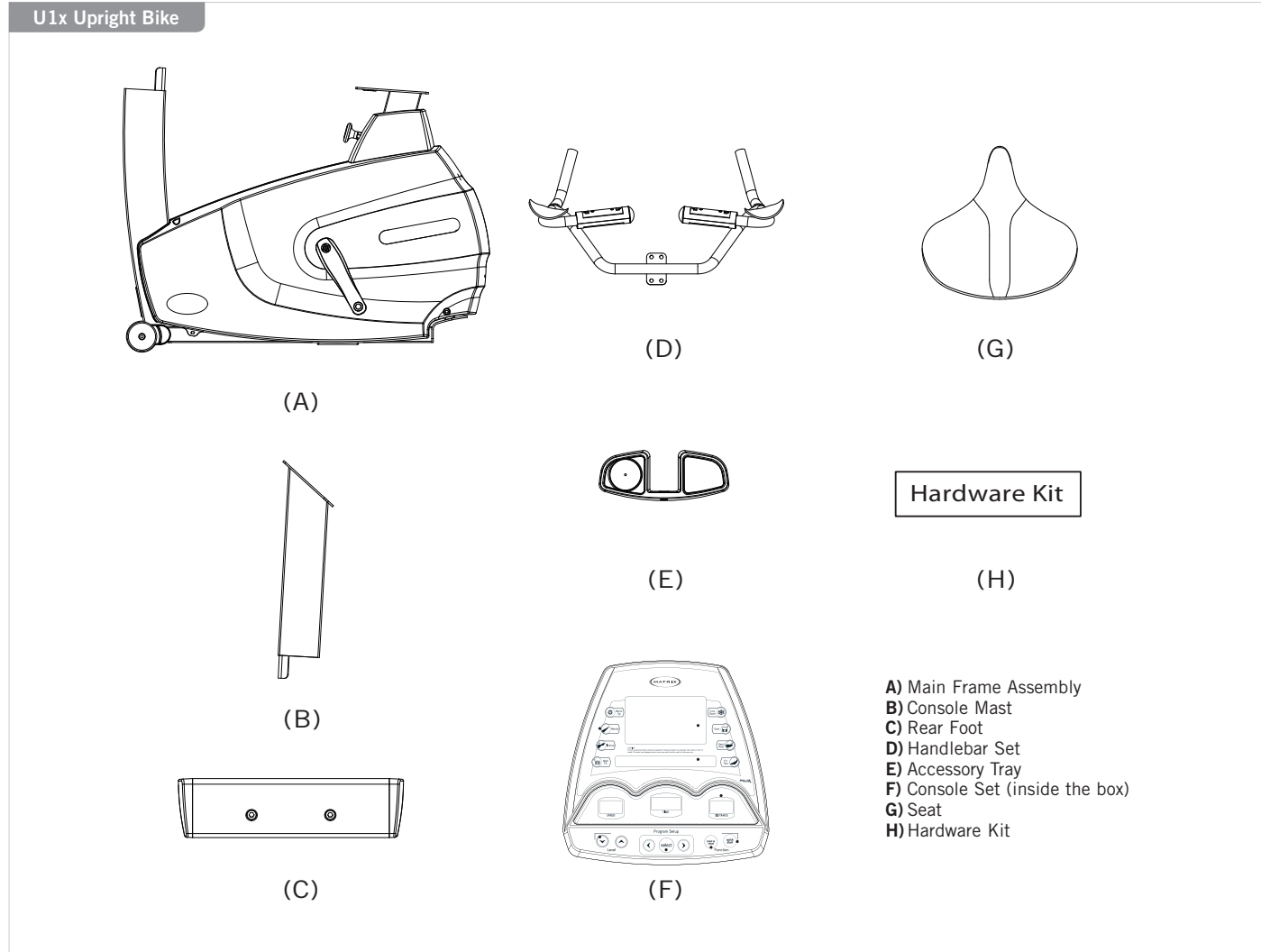

CHAPTER 2: SETUP

2.7 UNPACKING THE BIKES

The bike is carefully inspected before shipment so it should arrive in good operating condition. Matrix Fitness ships the unit in the following pieces:

R1x Recumbent Bike

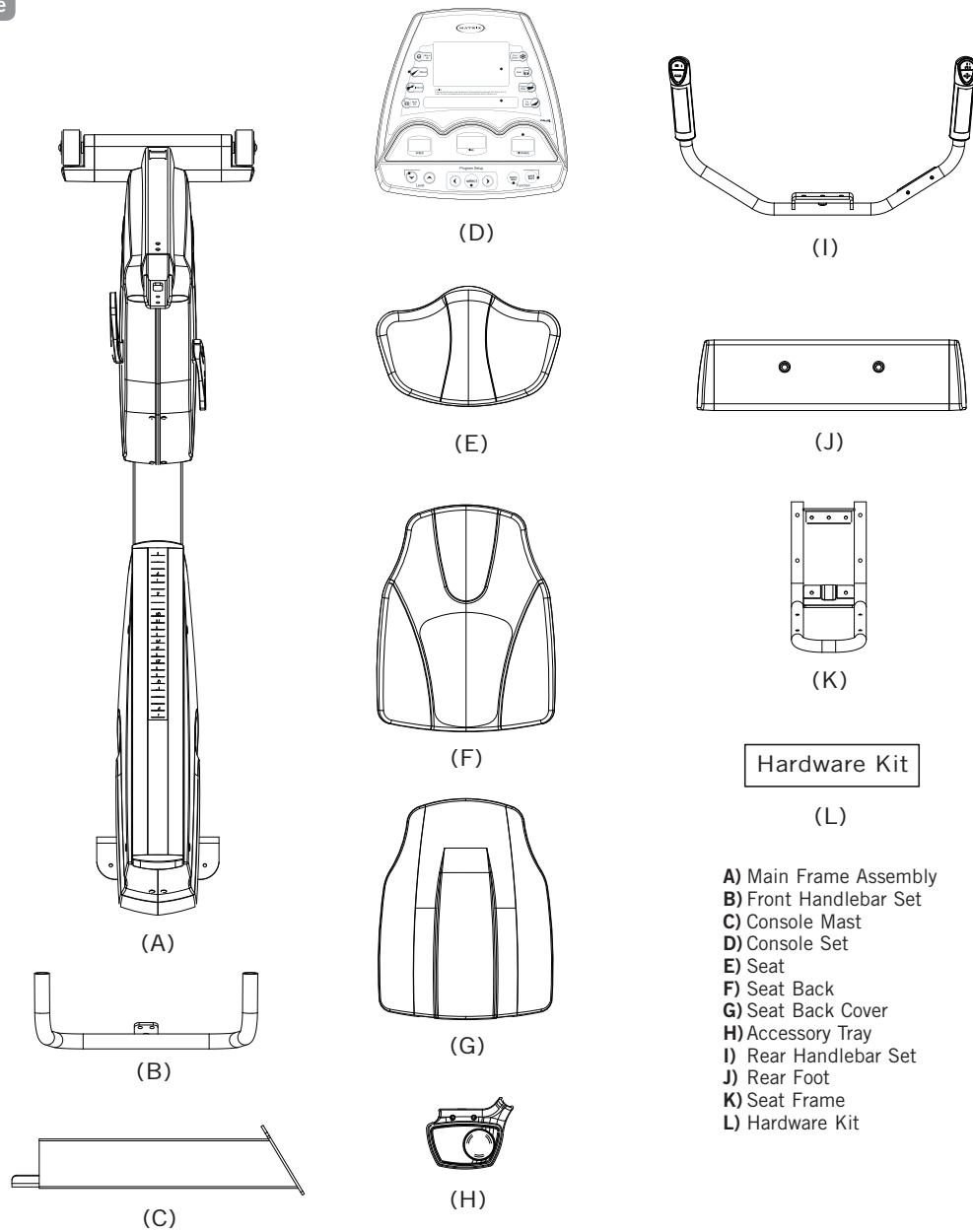

CHAPTER 3: Serial Number Location

3.1 SERIAL NUMBER LOCATION

RECUMBENT BIKE R1x

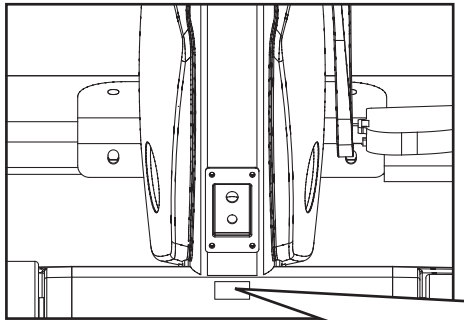

SERIAL # PLACEMENT

UPRIGHT BIKE U1x

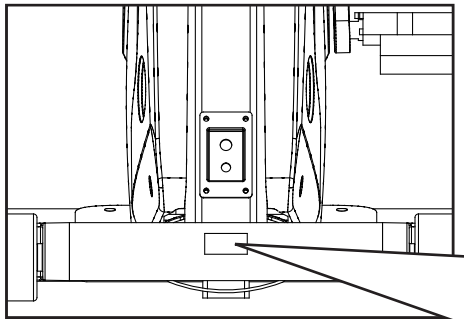





SERIAL # PLACEMENT

CHAPTER 4: BIKE PARTS AND ASSEMBLY GUIDES

4.1 FASTNERS U1x

UPRIGHT BIKE U1x

PARTS NO.	DESCRIPTION	QUANTITY	SKETCH	COLOR OF BAG	ASSEMBLY STEP
Z01	Button Head Bolt (M8×20L)	4		Yellow	STEP 1
Z01	Button Head Bolt (M8×20L)	4		Orange	STEP 3
Z01	Button Head Bolt (M8×20L)	4		Blue	STEP 4
Z08	Socket Head Screw (M5×25L)	2		Pink	

4.2 EXPLODED DIAGRAM U1x

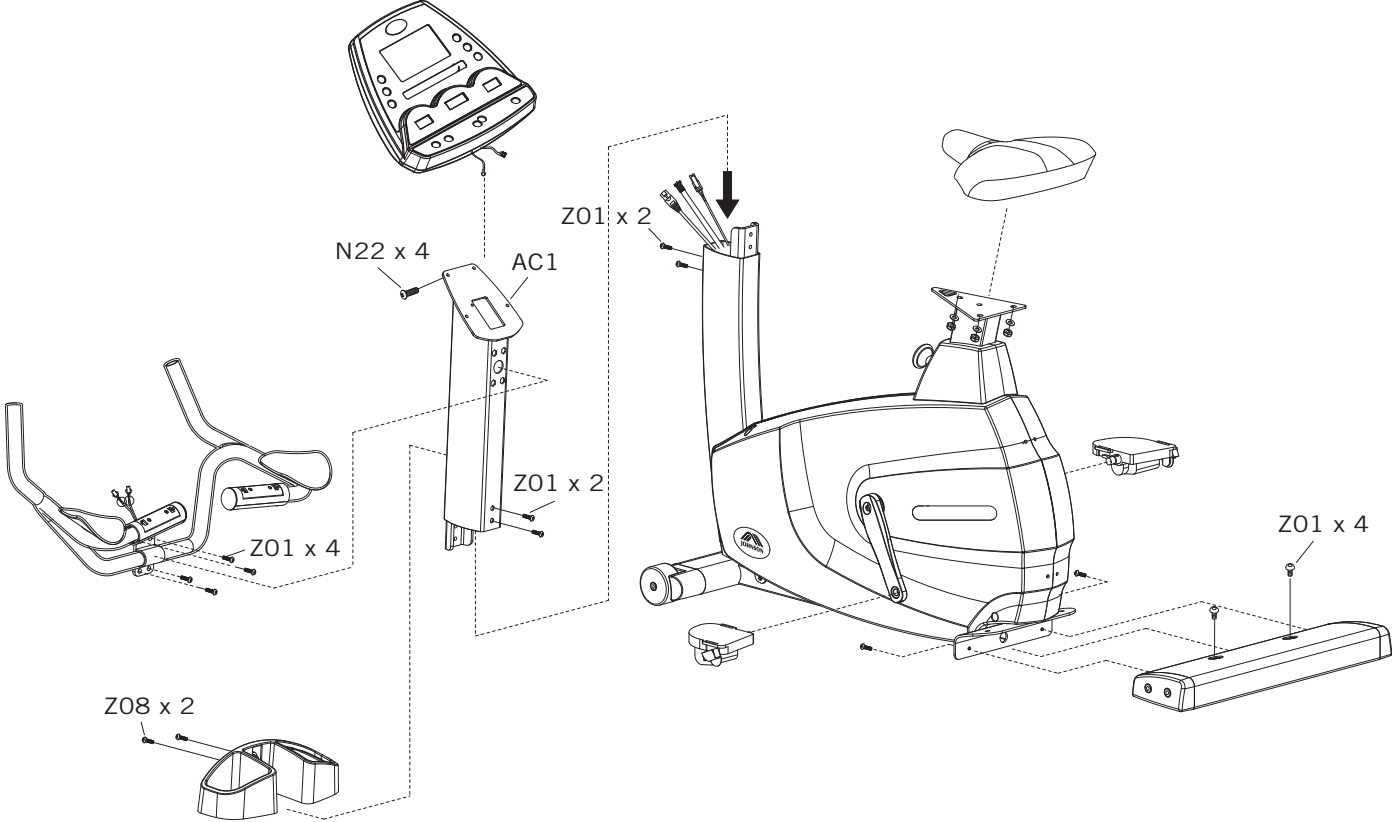

4.3 ASSEMBLY STEPS U1x

STEP 1

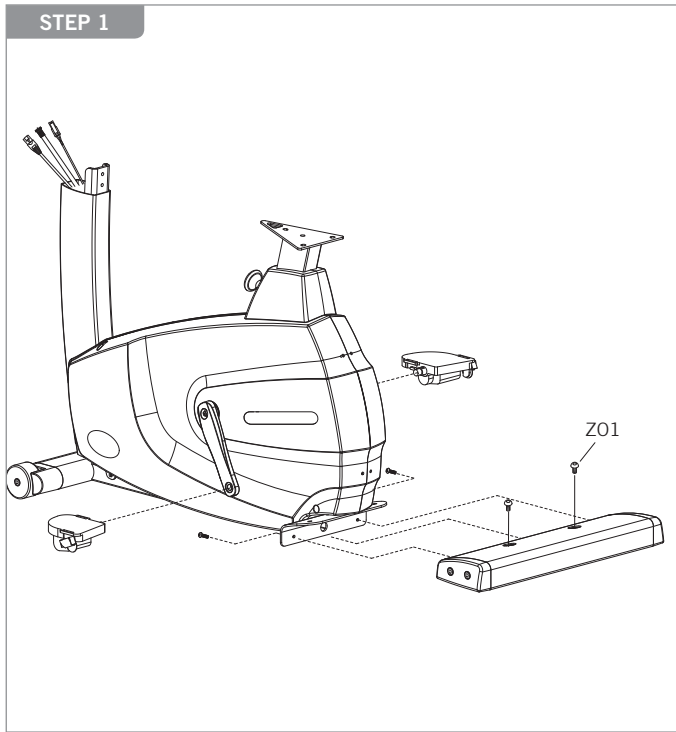

REAR FOOT

- 1) Install the **rear foot** in position at the rear of the bike with the mating holes in the frame bracket. Insert the four bolts (**Z01**) through the frame bracket and rear foot. Using a #6 Allen Wrench, tighten the screws completely.

PEDALS

- 1) Install the **pedals** on the **pedal cranks** using an Open Wrench. The Matrix logo of the pedal strap must point upward.
NOTE: Be careful to align the threads correctly to avoid damage. A little grease on the threads should help the pedals to screw in easily and correctly. Turn the left pedal spindle counterclockwise when threading into the crank arm, and turn the right pedal

STEP 2

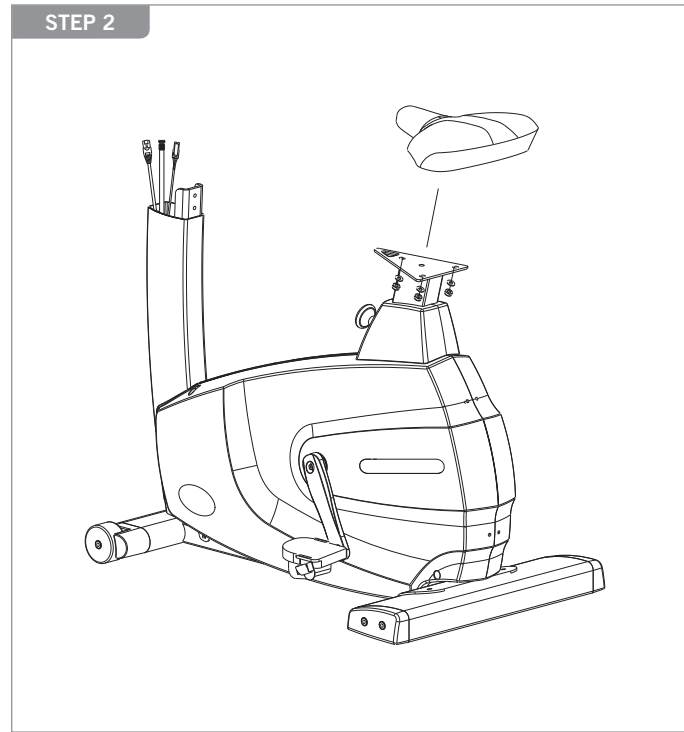

- 1) Remove the nuts from the bottom of the seat. Attach the **seat** to the **seat post** with the nuts you just removed. Tighten them with an Open Wrench.

4.3 ASSEMBLY STEPS U1x



- 1) Secure the **upper console mast** to the **lower console mast** using four bolts (**Z01**). Alternately tighten each bolt using a #6 Allen Wrench. Check the console mast to make sure it is securely fastened.

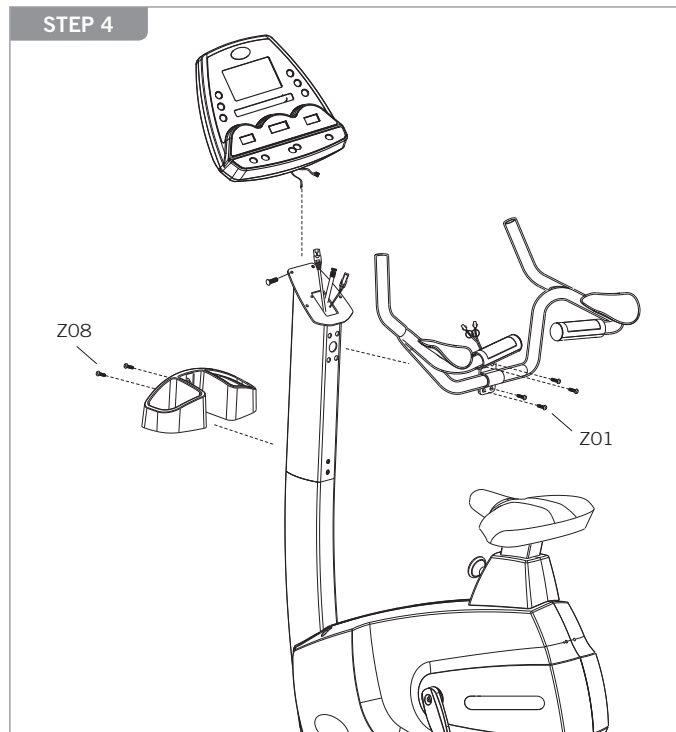

HANDLEBAR SET

- 1) Feed the **heart rate wires** of the **handlebar** through the small hole located in the front of the **console mast**. Pull these wires up through the hole at the top of the **console mast**. Attach the **handlebar** to the **console mast** using four bolts (**Z01**). Tighten with a #6 Allen Wrench.

CONSOLE

- 1) Remove the four mounting bolts from the back of the **console** with a Phillips Screwdriver. Plug in the wire harness and the two heart rate wires to the back of the **console**. Attach the **console** to the **console mast** with the four bolts removed earlier in this step.

ACCESSORY TRAY

- 1) Attach the **accessory tray** to the **console mast** using two screws (**Z08**). Tighten them with a Phillips Screwdriver.

4.3 ASSEMBLY STEPS U1x

ASSEMBLY COMPLETE

Assembly is complete.



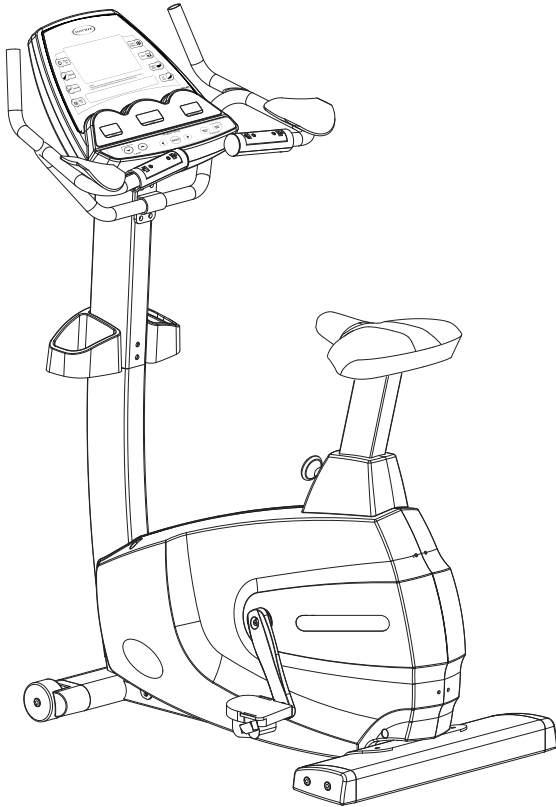



Final assembly and optional entertainment shown.



CHAPTER 4: BIKE PARTS AND ASSEMBLY GUIDES

4.4 FASTNERS R1x

UPRIGHT BIKE R1x

PARTS NO.	DESCRIPTION	QUANTITY	SKETCH	COLOR OF BAG	ASSEMBLY STEP
Z01	Spring Washer	8		White	STEP 4
Z02	Arc Washer	8		White	
Z03	Socket Button Head Screw (with Nyloc)	8		White	
Z13	Button Head Screw (Phillips)	2		White	
Z04	Socket Low Head Screw (with Nyloc)	4		Yellow	STEP 1
Z05	Socket Flat Head Screw	3		Red	STEP 3
Z04	Socket Low Head Screw (with Nyloc)	4		Blue	STEP 6
Z04	Socket Low Head Screw (with Nyloc)	4		Orange	STEP 5
Z09	Socket Button Head Screw (with Nyloc)	4		Black	STEP 2
Z10	Spring Wahser	4		Black	
Z11	Socket Head Screw	2		Black	
Z12	Spring Washer	2		Black	

4.5 EXPLODED DIAGRAM R1x

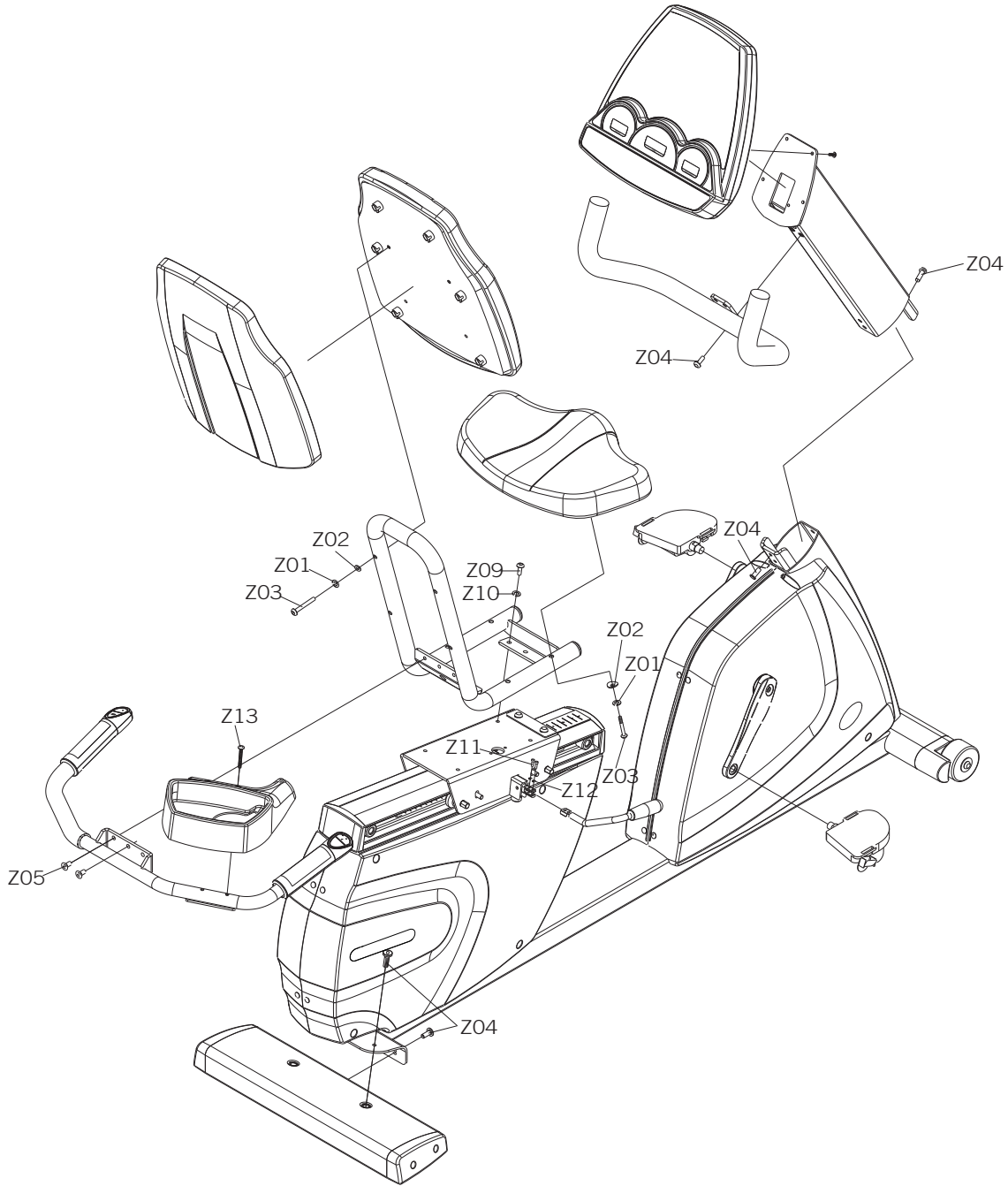

4.6 ASSEMBLY STEPS R1x

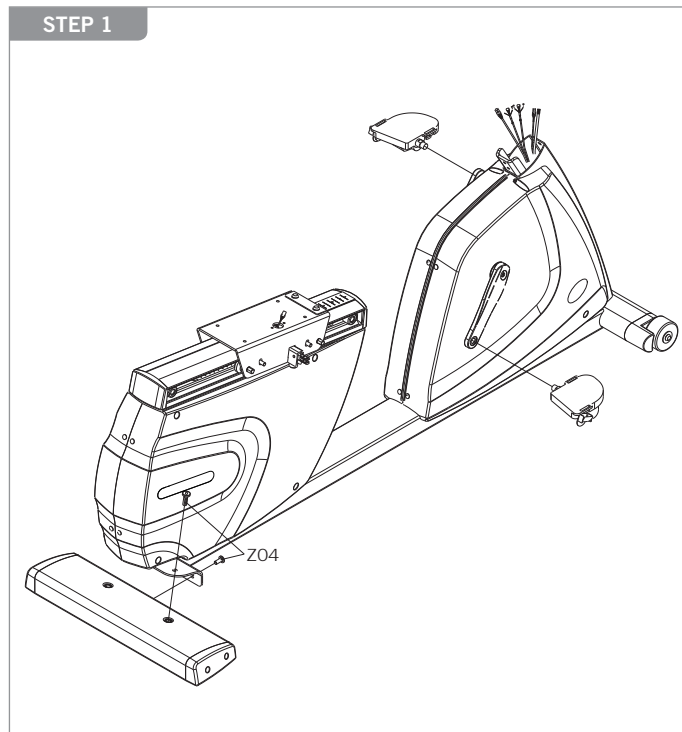

REAR FOOT

- 1) Install the **rear foot** in position at the rear of the bike with the mating holes in the frame bracket. Insert the four screws (**Z04**) through the **frame bracket** and **rear foot**. Using a #5 Allen Wrench tighten the screws securely.

PEDALS

- 1) Install the **pedals** on the **pedal cranks** using an Open Wrench. The Matrix logo on the pedal strap must point upward. **NOTE:** Be careful to align the threads correctly to avoid damage. A little grease on the threads should help the pedals to screw in easily and correctly. Turn the left pedal spindle counter clockwise when threading into the crank arm, and turn the right pedal spindle clockwise when threading into the crank arm.

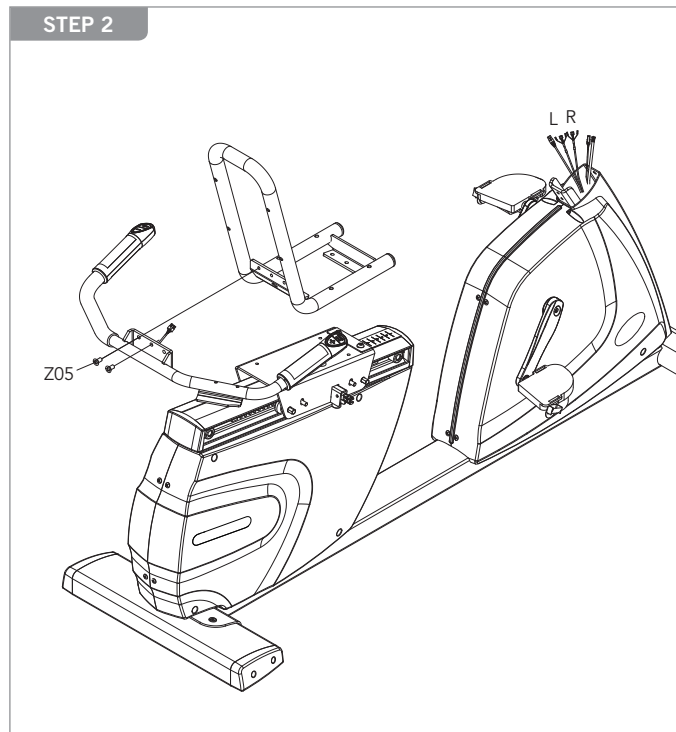

- 1) Pull the **heart rate wire** through the hole in the bottom of the **seat frame**, and make sure the wire get through the tunnel of the plate. Mount the **seat handlebars** to the **seat frame** by using three socket-flat-head screws (**Z05**).

4.6 ASSEMBLY STEPS R1x

STEP 3

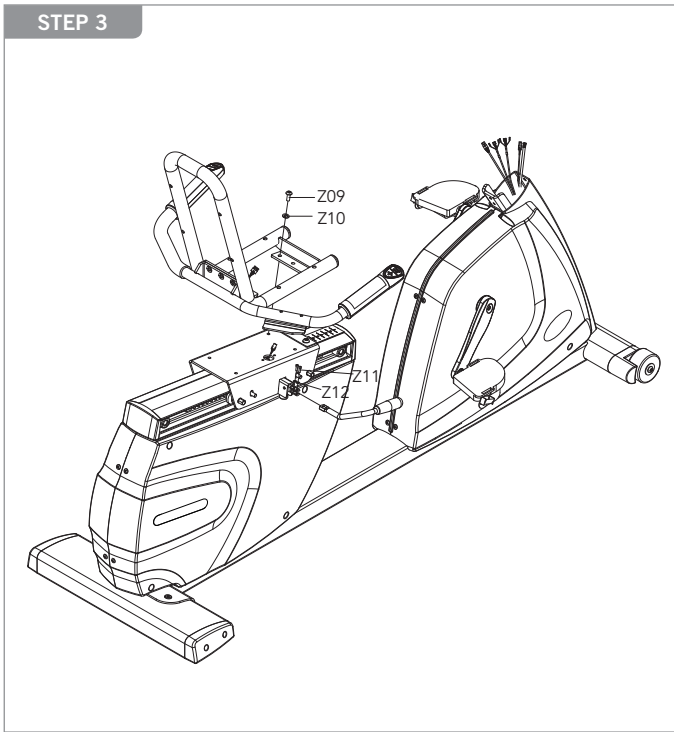

- 1) Install the **seat rail** on the **seat adjustment bracket** using the four washers (**Z10**) and screws (**Z09**). Tighten them with an #5 Allen Wrench.
- 2) Connect the wire harness from the **seat handlebar** to the wire harness coming from the **seat frame**.
- 3) Slide the **seat adjustment handle** between the teeth of the **seat adjustment bracket**.

STEP 4

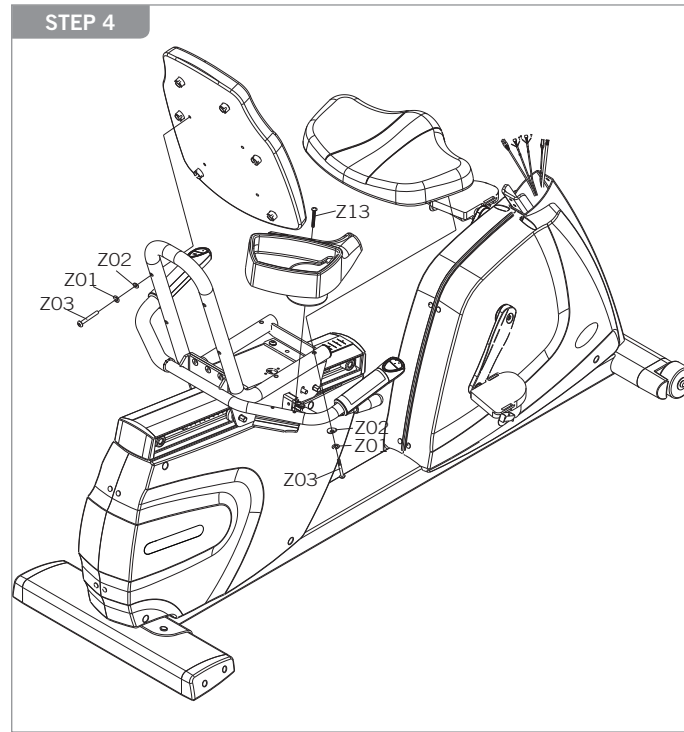

ACCESSORY

- 1) Secure the **accessory tray** to the **seat handlebar** with two button-head screws (**Z13**). Be careful when inserting the bolts to clear the wires inside the handlebar to prevent damage. Tighten with a Philips screwdriver.

SEAT AND SEATBACK

- 1) Mount the **seat** to the **seat frame** with four arc washers (**Z02**), spring washers (**Z01**) and socket button-head screws (**Z03**). Tighten with a #5 Allen Wrench. Mount the seatback to the seat frame with four arc washers (**Z02**), spring washers (**Z01**) and socket button-head screws (**Z03**). Tighten with a #5 Allen Wrench.

4.6 ASSEMBLY STEPS R1x

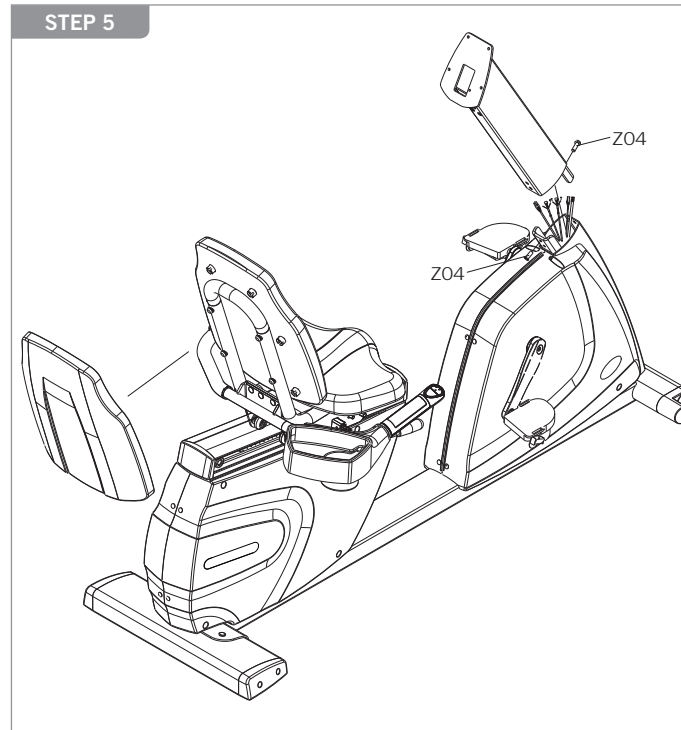

SEATBACK COVER

- 1) Attach the **seatback cover** to the **seatback**.

CONSOLE MAST

- 1) Secure the **upper console mast** to the **lower console mast** using the four screws (**Z04**). Alternately tighten each bolt using a #5 Allen Wrench. Check the **console mast** to make sure it is securely fastened.

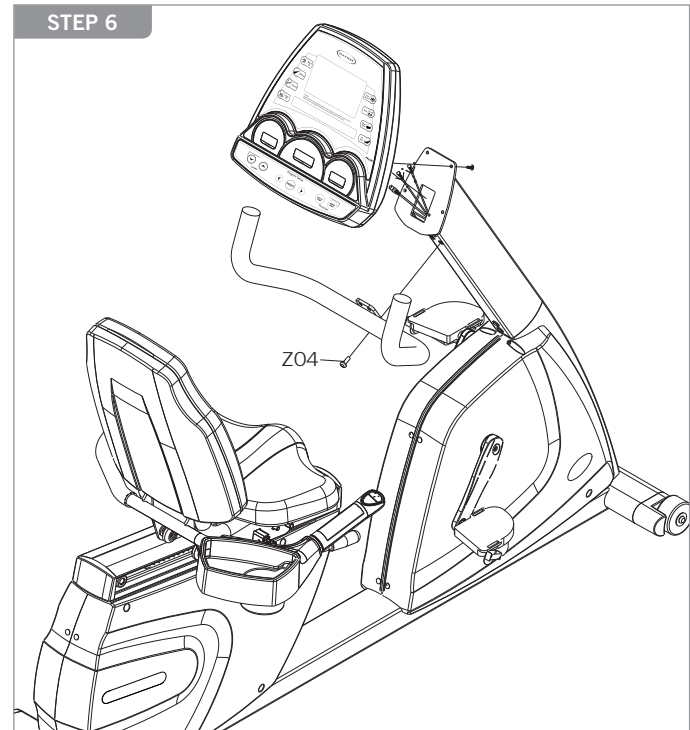

HANDLEBAR

- 1) Mount the upper **handlebars** to the **console mast** using four screws (**Z04**). Tighten with a #5 Allen Wrench

CONSOLE

- 1) Remove the four mounting bolts from the back of the **console**. Connect the wire harnesses and heart rate wires that come from the **console mast** into the plugs located in the back of the **console**. Attach the **console** to the **mast** with the four bolts removed earlier.

4.6 ASSEMBLY STEPS R1x

ASSEMBLY COMPLETE

Assembly is complete.

Final assembly and optional entertainment shown.

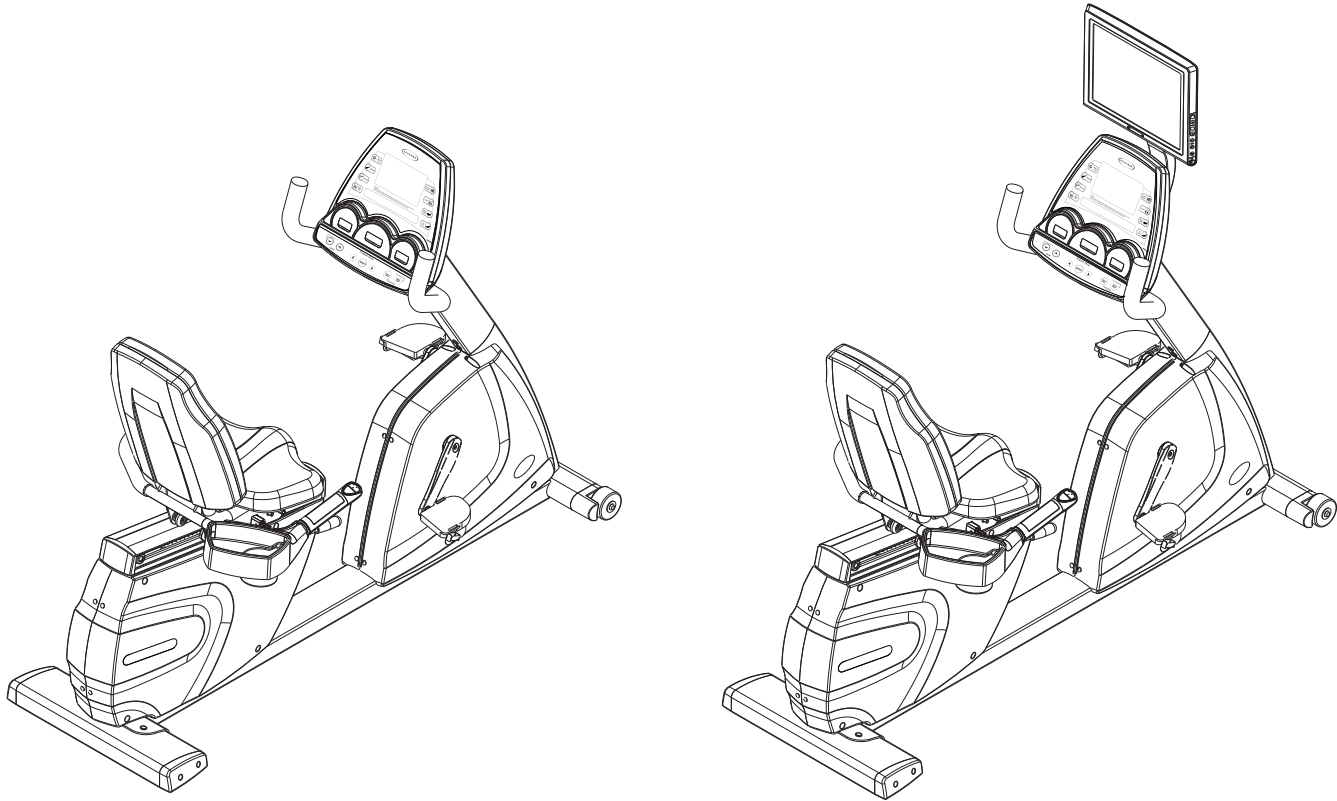

5.1 CONSOLE DISPLAY

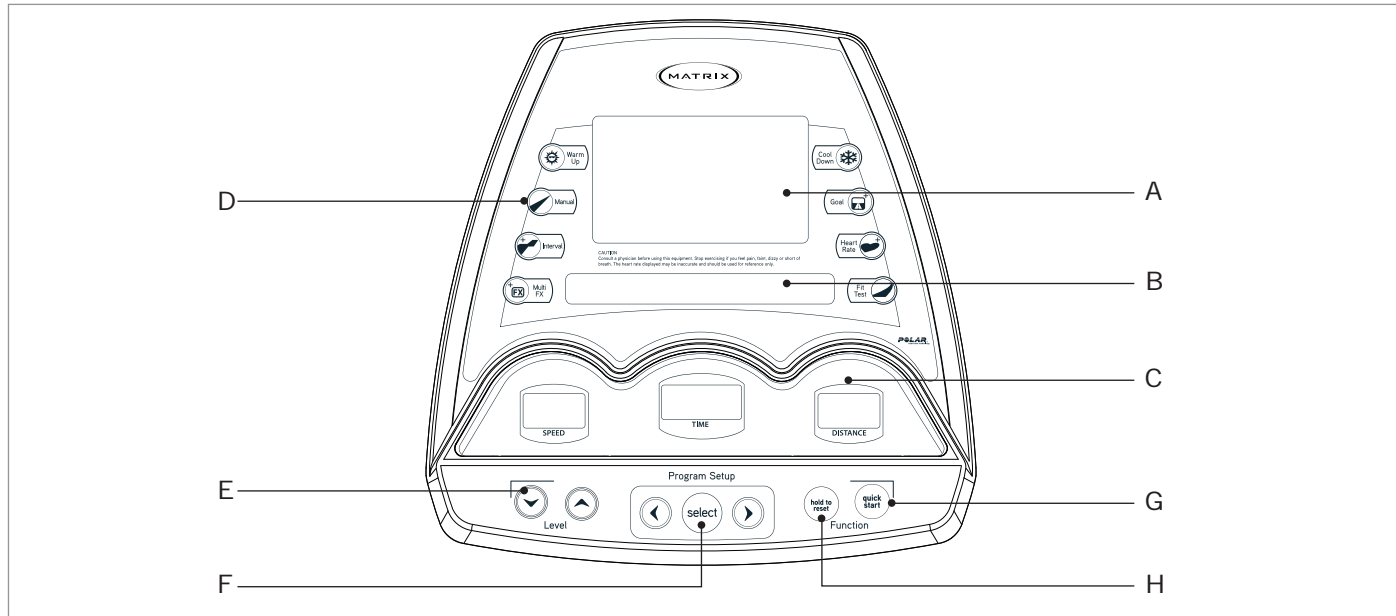

A) WORKOUT PROFILE WINDOW:

During a workout, this window displays shapes, made of triangle columns of lights, which represent the levels of intensity in a workout-in-progress. The height of the furthest column is proportional to the current level of the intensity. Information will cycle every 30 seconds.

B) INSTRUCTION CENTER:

This window displays step-by-step instructions for setting up a workout.

C) INFORMATIONAL DISPLAY:

During a workout, three sets of numbers, including Speed, Time and Distance, display statistics about the progress of the workout.

D) PROGRAM PLUS™ KEYS

Press the key to select one of the workouts. The program key with a symbol of plus “+” represents additional workout options. Press this key repeatedly for similar workout options.

E) LEVEL ARROW KEYS

During a workout, pressing the UP or DOWN arrow can adjust intensity levels.

F) RIGHT / LEFT ARROW KEYS

A pair of RIGHT and LEFT arrows is located on the side of SELECT. Use arrows, when setting up a workout, to change workout parameters displayed on the LCD console, such as length of workout, weight, age, heart rate, and intensity level. In addition, the pair of RIGHT and LEFT arrows is corresponding to the arrows in the LCD display.

G) QUICK START

Press QUICK START to begin your workout immediately, without having to select a workout program.

H) RESET

PAUSE: If you need to PAUSE your program during a workout, stop pedaling. It will PAUSE your program for 30 seconds. Pressing START will return you to your workout. **NOTE:** Pause time is only available for ellipticals equipped with the battery.

RESET: If you need to RESET the console during your workout, you can do so by holding down the RESET button for three seconds, or until the display resets.

5.2 WORKOUT PARAMETER PROMPTS

This section lists the default value and value range of workout parameters appeared in the PROMPT AREA, located in the bottom of WORKOUT PROFILE WINDOW. Before an exercise session, each parameter prompt will appear here depending on different programs.

PROMPT	DEFAULT	MINIMUM	MAXIMUM	UNIT
TIME	20	5	99	minute
LEVEL	1	1	20	
WEIGHT	68 / 150	34 / 75	182 / 400	kg / lbs
AGE	30	10	99	years old
DISTANCE	5 / 3	1 / 1	80 / 50	km / mile
CALORIES	500	50	5000	cal.
WATTS	150	50	350	watt
Heart Rate	n/a	52	200	beat
GENDER	MALE	MALE	FEMALE	

NOTE: The workout time is a "countdown" display according to the default time or the maximum time that a user inputs. When the workout time is inputted as "0", the time will count up from a zero to the maximum time.

5.3 WORKOUT OVERVIEWS

This chart lists the bike's pre-programmed workouts.

PROGRAM NAME		DESCRIPTION	DEFAULT TIME	PROMPT INPUT
QUICK START		Quick Start is the fastest way to begin exercising and bypasses the setup prompts. After pressing the QUICK START key, a constant-level workout begins.	N/A	N/A
WARM UP		Warm-up is a low-intensity phase that brings the heart rate into the lower end of the target zone and increases respiration and blood flow to working muscles.	N/A	Time
COOL DOWN		Cool-down is a low-intensity phase that allows the body to begin removing lactic acid, and other exercise by-products, which build up in muscles and contribute to soreness.	N/A	Time
MANUAL		Manual is a constant intensity level unless it is manually changed.	20 min	Time, Weight
INTERVAL+	HILL INTERVAL	Hill Interval is an efficient workout by alternating work intervals and recovery intervals.	20 min	Level, Time, Weight
	RANDOM HILL	Random Hill is an interval training workout that occurs in no regular pattern or progression.	20 min	Time, Weight
MULTI FX+	CONSTANT WATTS	Constant Watts is designed to maintain your watts expenditure at a constant level by controlling pedaling resistance and prompting you to pedal at a specified RPM. Watts level may vary above and below your target watts level during this program.	20 min	Watts, Time, Weight
	RANDOM	Random is a workout of constantly changing intensity levels that occur in no regular pattern or progression.	20 min	Level, Time, Weight

5.3 WORKOUT OVERVIEWS

PROGRAM NAME		DESCRIPTION	DEFAULT TIME	PROMPT INPUT
GOAL+	TIME GOAL	Time Goal sets exercise duration as the workout goal. Once the objective is met, the workout automatically goes into a cool-down phase and ends afterward.	20 min	Time, Weight
	DISTANCE GOAL	Distance Goal is designed to build endurance in a certain distance. Once the objective is met, the workout automatically goes into a cool-down phase, and ends afterward.	N/A	Distance, Weight
	CALORIES GOAL	Calories Goal is designed to burn a certain number of selected calories. Once the objective is met, the workout automatically goes into a cool-down phase and ends afterward.	N/A	Calories, Weight
HEART RATE+	TARGET HR	Target HR is a higher intensity workout for maintaining a heart rate to achieve maximum exercise results. The user must wear a heart rate chest strip, or keep hands on contact heart rate grips continuously. The program adjusts the intensity level, based on the actual heart rate, to maintain the rate at 80 percent of the theoretical maximum.	20 min	Age, HR, Time, Weight
	WEIGHT LOSS	Weight Loss is a low-intensity workout for burning the body's fat reserves. The user must wear a heart rate chest strip, or keep hands on contact heart rate grips continuously. The program adjusts the intensity level, based on the actual heart rate, to maintain the rate at 65 percent of the theoretical maximum.	20 min	Age, HR, Time, Weight
FIT TEST		Fit Test measures cardiovascular fitness and can be used to monitor improvements in your endurance.	12 min	Gender, Age, Level, Weight

5.4 WORKOUT TIPS

- 1) Matrix Fitness strongly recommends seeing your physician for a complete physical examination before beginning any fitness program. Know your physician-recommended heart rate target zone. If, at any time while exercising, you experience faintness, dizziness, pain, or shortness of breathe, you must stop immediately.
- 2) To mount the bike, grasp the front stationary handlebars and place your feet on the pedals. When you are comfortably situated, begin pedaling. To dismount the bike, stop pedaling, grasp the front stationary handlebars and get off the unit.
- 3) It is highly recommended that you always incorporate the warm-up and cool-down period into your workout. Warm-up brings the heart rate into the lower end of the target zone and increases respiration and blood flow to working muscles. Cool-down takes time for a user's heart rate to return to a resting state after vigorous exercise and reduces the amount of lactic acid in muscle tissue.

5.5 WORKOUT SETUP STEPS

Different bike workouts require different setup procedures. This section provides details for settling up any workout program.

- 1) Begin to pedal the bike.
- 2) Use the PROGRAM PLUS™ KEYS to enter the program, or use RIGHT / LEFT ARROW keys to scroll to desired program. The program name is displayed in the PROMPT AREA.
- 3) Use the RIGHT / LEFT ARROW keys to scroll to desired parameter values displayed in the PROMPT AREA.
- 4) Press the SELECT key to confirm each selection. Follow the steps to set up each workout.

NOTE: The PROGRAM PLUS™ KEYS with a symbol of plus "+" have couple of similar workout options included. Press the key repeatedly to select the desired program. Or, press the program key once and use RIGHT / LEFT ARROW keys to scroll to the desired program.

QUICK START

Press the "QUICK START" key and the WORKOUT PROFILE WINDOW will display "3, 2, 1, GO!" The workout begins at the default intensity level, and the workout time counts up from "0" to the maximum workout time.

WARM UP

- 1) Press the "WARM-UP" key to enter the program.
- 2) "SELECT TIME" using the RIGHT / LEFT ARROW keys, and then press SELECT.
- 3) Press START to begin a warm-up.

COOL DOWN

- 1) Press the "COOL-DOWN" key to enter the program.
- 2) "SELECT TIME" using the RIGHT / LEFT ARROW keys, and then press SELECT.
- 3) Press START to begin a cool-down.

MANUAL

- 1) Press the "MANUAL" key to enter the program.
- 2) "SELECT TIME" using the RIGHT / LEFT ARROW keys, and then press SELECT.
- 3) "SELECT WEIGHT" using the RIGHT / LEFT ARROW keys, and then press SELECT.
- 4) Press START to begin the workout.

5.5 WORKOUT SETUP STEPS

INTERVAL +

A) HILL INTERVAL

- 1) Repeatedly Press the "INTERVAL+" key to select "HILL INTERVAL", and then press SELECT.
- 2) "SELECT LEVEL" using the RIGHT / LEFT ARROW keys, and then press SELECT.
- 3) "SELECT TIME" using the RIGHT / LEFT ARROW keys, and then press SELECT.
- 4) "SELECT WEIGHT" using the RIGHT / LEFT ARROW keys, and then press SELECT.
- 5) Press START to begin the workout.

B) RANDOM HILL

- 1) Repeatedly Press the "INTERVAL+" key to select "RANDOM HILL", and then press SELECT.
- 2) "SELECT TIME" using the RIGHT / LEFT ARROW keys, and then press SELECT.
- 3) "SELECT WEIGHT" using the RIGHT / LEFT ARROW keys, and then press SELECT.
- 4) Press START to begin the workout.

MULTI FX +

A) CONSTANT WATTS

- 1) Repeatedly Press the "MULTI FX+" key to select "CONSTANT WATTS", and then press SELECT.
- 2) "SELECT WATTS" using the RIGHT / LEFT ARROW keys, and then press SELECT.
- 3) "SELECT TIME" using the RIGHT / LEFT ARROW keys, and then press SELECT.
- 4) "SELECT WEIGHT" using the RIGHT / LEFT ARROW keys, and then press SELECT.
- 5) Press START to begin the workout.

B) RANDOM

- 1) Repeatedly Press the "MULTI FX+" key to select "RANDOM ", and then press SELECT.
- 2) "SELECT LEVEL" using the RIGHT / LEFT ARROW keys, and then press SELECT.
- 3) "SELECT TIME" using the RIGHT / LEFT ARROW keys, and then press SELECT.
- 4) "SELECT WEIGHT" using the RIGHT / LEFT ARROW keys, and then press SELECT.
- 5) Press START to begin the workout.

GOAL +

A) TIME GOAL

- 1) 1) Repeatedly Press the "GOAL+" key to select "TIME GOAL", and then press SELECT.
- 2) 2) "SELECT TIME" using the RIGHT / LEFT ARROW keys, and then press SELECT.
- 3) 3) "SELECT WEIGHT" using the RIGHT / LEFT ARROW keys, and then press SELECT.
- 4) 4) Press START to begin the workout.

B) DISTANCE GOAL

- 1) 1) Repeatedly Press the "GOAL+" key to select "DISTANCE GOAL", and then press SELECT.
- 2) 2) "SELECT DISTANCE" using the RIGHT / LEFT ARROW keys, and then press SELECT.
- 3) 3) "SELECT WEIGHT" using the RIGHT / LEFT ARROW keys, and then press SELECT.
- 4) 4) Press START to begin the workout.

C) CALORIES GOAL

- 1) 1) Repeatedly Press the "GOAL+" key to select "CALORIES GOAL", and then press SELECT.
- 2) 2) "SELECT CALORIES" using the RIGHT / LEFT ARROW keys, and then press SELECT.
- 3) 3) "SELECT WEIGHT" using the RIGHT / LEFT ARROW keys, and then press SELECT.
- 4) 4) Press START to begin the workout.

5.5 WORKOUT SETUP STEPS

HEART RATE +

A) TARGET HR / WEIGHT LOSS

- 1) Repeatedly Press the "HEART RATE+" key to select "TARGET HR" or "WEIGHT LOSS", and then press SELECT
- 2) "SELECT AGE" using the RIGHT / LEFT ARROW keys, and then press SELECT.
- 3) "SELECT HR" using the RIGHT / LEFT ARROW keys, and then press SELECT.
- 4) "SELECT TIME" using the RIGHT / LEFT ARROW keys, and then press SELECT.
- 5) "SELECT WEIGHT" using the RIGHT / LEFT ARROW keys, and then press SELECT.
- 6) Press START to begin the workout.

B) FIT TEST

- 1) "SELECT GENDER" using the RIGHT / LEFT ARROW keys, and then press SELECT.
- 2) "SELECT AGE" using the RIGHT / LEFT ARROW keys, and then press SELECT.
- 3) "SELECT LEVEL" using the RIGHT / LEFT ARROW keys, and then press SELECT.
- 4) "SELECT WEIGHT" using the RIGHT / LEFT ARROW keys, and then press SELECT.
- 5) Press START to begin the workout.

The tables below list fit test results:

FIT TEST'S RESULT FOR MALE

Male		Estimated VO2 Max (ml/kg/min) Per Age Category				
Age \ Rating	Very Poor	Poor	Fair	Good	Excellent	Superior
15 – 19	< 35.0	35.0 – 38.3	38.4 – 45.1	45.2 – 50.9	51.0 – 55.9	> 55.9
20 – 29	< 33.0	33.0 – 36.4	36.5 – 42.4	42.5 – 46.4	46.5 – 52.4	> 52.4
30 – 39	< 31.5	31.5 – 35.4	35.5 – 40.9	41.0 – 44.9	45.0 – 49.4	> 49.4
40 – 49	< 30.2	30.2 – 33.5	33.6 – 38.9	39.0 – 43.7	43.8 – 48.0	> 48.0
50 – 59	< 26.1	26.1 – 30.9	31.0 – 35.7	35.8 – 40.9	41.0 – 45.3	> 45.3
60 +	< 20.5	20.5 – 26.0	26.1 – 32.2	32.3 – 36.4	36.5 – 44.2	> 44.2

FIT TEST'S RESULT FOR FEMALE

Female		Estimated VO2 Max (ml/kg/min) Per Age Category				
Age \ Rating	Very Poor	Poor	Fair	Good	Excellent	Superior
15 – 19	<25.0	25.0 – 30.9	31.0 – 34.9	35.0 – 38.9	39.0 - 41.9	>41.9
20 – 29	<23.6	23.6 – 28.9	29.0 – 32.9	33.0 – 36.9	37.0 - 41.0	>41.0
30 – 39	<22.8	22.8 – 26.9	27.0 – 31.4	31.5 – 35.6	35.7 - 40.0	>40.0
40 – 49	<21.0	21.0 – 24.4	24.5 – 28.9	29.0 – 32.8	32.9 - 36.9	>36.9
50 – 59	<20.2	20.2 – 22.7	22.8 – 26.9	27.0 – 31.4	31.5 - 35.7	>35.7
60 +	<17.5	17.5 – 20.1	20.2 – 24.4	24.5 - 30.2	30.3 - 31.4	>31.4

5.6 USING FITNESS NETWORK

The two RJ45 networking ports are equipped in both the upright and recumbent bike. These ports allow the bike to be connected to a fitness entertainment system and/or a fitness network, such as FitLinxx®.

C-SAFE / CARDIO PORT

The ports are located on the back of the console. The C-SAFE port enables the bike to upload user workout statistics to a fitness network database. The CARDIO port is compatible to entertainment protocol such as Cardio Theater® or BroadcastVision™.

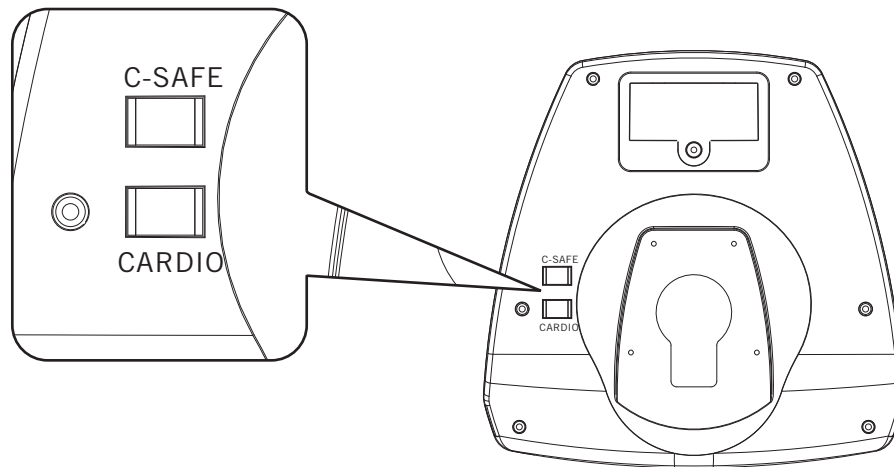

CHAPTER 6: MANAGER'S CUSTOM MODE

6.1 LIST OF MANAGER'S CUSTOM MODE

The Manager's Custom Mode allow the club owner to customize the bike for the club.

To enter the Manager's Custom Mode, press and hold down the “**LEVEL ARROW keys**” . Continue to hold down these two keys until the **INSTRUCTION CENTER** displays “**MANAGER MENU**”.

1. To scroll through the list of Manager's Custom Mode, use the “**LEFT / RIGHT ARROW keys**”, or “**LEVEL ARROW keys**”. The **INSTRUCTION CENTER** will display, in turn, each of custom settings.
2. To select a custom mode, press the **SELECT** key to enter.
3. To change the value of the setting, use the “**LEFT / RIGHT ARROW keys**”, or “**LEVEL ARROW keys**”.
4. To confirm and save the value of the setting, press the **QUICK START** key. “**SETTING SAVED**” will appear in the **INSTRUCTION CENTER**. To exit the setting without saving, press the **RESET** key within 5 seconds, or if there is no key pressed, the system will resume automatically.

LIST OF MANAGER'S CUSTOM MODES:

	CUSTOM SETTING	DEFAULT	MINIMUM	MAXIMUM	UNIT	STEP	DESCRIPTION
P0	MAXIMUM TIME	99 min	20 min	99 min	minute	1	Enable fitness club managers to set the program maximum workout duration limits during peak and non-peak hours of club traffic. Active variable displayed in the TIME display after change.
P1	DEFAULT TIME	20 min	5 min	max. time	minute	1	Control the default program time.
P2	DEFAULT LEVEL	1	1	10	n/a	1	Control the starting resistance level for all programs.
P3	MAXIMUM LEVEL	20	1	20	n/a	1	Enable to set maximum resistance level for all programs.
P4	DEFAULT WEIGHT	68kg / 150lbs	34kg / 75lbs	182kg / 400lbs	kg/lbs	1	Control the default weight used in calorie calculations. Set to default unit change (kilograms or pounds). Displayed in native units.
P5	DEFAULT AGE	30	10	99	age	1	Control the default users age used in target heart rate calculations.
P6	ACCUMULATED DISTANCE	N/A	0	104,000 km / 65,000 mile	km / mile	N/A	Accumulated distance is not editable, but only for display. Displayed in native units (miles or kilometers). After the equipment reaches the maximum distance, it will reset to "0" automatically.

6.1 LIST OF MANAGER'S CUSTOM MODE

	CUSTOM SETTING	DEFAULT	MINIMUM	MAXIMUM	UNIT	STEP	DESCRIPTION
P7	ACCUMULATED TIME	N/A	0	65,000 hrs	hour	N/A	Accumulated time is not editable, but only for display. After the machine reaches the maximum time, it will reset to "0" automatically.
P8	PAUSE TIME	30 sec	30 sec	180 sec	second	1	This is the maximum time during which a workout can remain in pause mode. Restrictions exist for the machine not equipped with a battery.
P9	MODEL	EL	N/A	N/A	N/A	N/A	CB - Upright Bike RB - Recumbent Bike EL - Elliptical Trainer ST - Stepper
P10	LANGUAGE	English	N/A	N/A	N/A	N/A	The native language prompts in the INSTRUCTION CENTER.
P11	SOFTWARE VERSION	N/A	N/A	N/A	N/A	N/A	Software version is not editable, but only for display.
P12	UNITS	English	English	Metric	N/A	N/A	The measurement unit prompts for weight, distance, and speed.
P13	ERROR LOG	N/A	N/A	N/A	N/A	N/A	Error log is not editable, but only for display. Holding the Left and Right Arrow keys simultaneously to erase the error log.
P14	METS	OFF	ON	OFF	N/A	N/A	If this option is "ON", the METs prompt becomes an individual display in PROMPT AREA. If "OFF", there will be an alternate prompt in RPM and METs at the lower-right corner of the WORKOUT PROFILE WINDOW.
P15	RESET ALL	N/A	N/A	N/A	N/A	N/A	The function would clear all custom settings had stored on the unit and all settings return to manufacturer default value. Holding the Left and Right Arrow keys simultaneously to clear all custom settings values.

MAINTENANCE

The Matrix R1x/U1x are built for commercial use 12 hours a day and seven days a week. However, as a club manager or owner, you are responsible for cleaning and maintaining the unit's integrity. If you fail to maintain the bike as described below, it could affect or void the Matrix limited warranty.

NOTE: Safety of the equipment can be maintained only if the equipment is examined regularly for damage or wear. Keep the equipment out of use until defective parts are repaired or replaced. Pay special attention to parts that are subject to wear, such as display console, console mounting screws, handrails, link arms, pedal arms and pedals.

7.1 DAILY INSPECTION

Look and listen for loose fasteners, unusual noises, and any other indications that the equipment may be in need of service. If you notice any of these, obtain service.

7.2 DAILY MAINTENANCE

Matrix Fitness recommends the R1x/U1x be cleaned before and after each workout. The following daily maintenance tips will keep your unit operating at peak performance:

- 1) Use a damp, soft cloth with water or mild liquid detergent to clean all exposed surfaces. DO NOT use ammonia, chlorine, or acid-based cleaners.
- 2) Keep the display console free of fingerprints and salt build-up caused by sweat.
- 3) Frequently vacuum the floor underneath the unit to prevent the accumulation of dust and dirt, which can affect the smooth operation of the unit.

7.3 MONTHLY MAINTENANCE

Perform the following services each month, or as needed:

- 1) Check that the console, handrails, link arms, pedal arms and pedals are secure.

7.4 RECYCLING THE BATTERY

When the Matrix bike is about to be discarded at the end of its useful life, the rechargeable battery must first be removed and recycled. If the bike is being equipped with the battery, to access the battery, unscrew the cover on the back of the console. To remove the battery, disconnect the cable.

CHAPTER 8: PRODUCT SPECIFICATIONS

	U1x	R1x
CONSOLE		
Display Screen	Workout Profile Window – 7” blue backlit graphic LCD display	
	Instruction Center – 14-character red LED alphanumeric display	
	Informational Display – 3 numeric 7-segment display (3 sets)	
Display Readout	Time, Distance, Calories, Speed, Level, Watts, METS, Heart Rate, Profile	
Programs	Manual, Interval+(Hill Interval, Random Hill), Goal+(Time Goal, Distance Goal, Calories Goal), Multi FX+(Constant Watts, Random), Heart Rate+(Target HR, Weight Loss), Fit Test, Warm Up, Cool Down	
On-the-fly Program Change	Yes	
Telemetric Receiver	Yes	
Contact HR Sensors	Yes	
Program Quick Keys	Yes	
One-Touch Quick Start	Yes	
Pause Time	30 seconds	
Language Options	English, Italian, German, Spanish, French, Dutch, Portuguese, Japanese	
TECHNICAL DATA		
Resistance Technology	JID™ hybrid generator	
Resistance Levels	20	
Drive System	One stage belt-driven	
Seat Adjustments	12 positions	25 positions
Dimension (L x W x H)	103 x 65 x 131 cm / 41” x 26” x 52”	167 x 68 x 128 cm / 66” x 27” x 50”
Product Weight	63.5 kg / 140 lbs	85 kg / 188 lbs
Max User Weight	182 kg / 400 lbs	
Power Requirement	Self-powered	
SPECIAL FEATURES		
Step-thru Design	N/A	Yes
Handlebar Design	Ergonomic elbow rests design with integrated contact HR handgrips	Front stationary handlebars and racing handlebars integrated contact HR handgrips
Pedals	Extra large pedals with ratcheted strap adjustments	
Seat Design	Contoured shape seat	Comfort seat and stylish seat back
Ratcheting Seat Adjustment	Yes	N/A
Remote Operation Keys	N/A	Yes
Integrated Reading Rack	Yes	
Accessory Tray	Yes	
ENTERTAINMENT SOLUTIONS		
Matrix® LCD TV Mount	Yes	
Networking Capabilities	Yes	

*Product specifications are subject to change without notice.





Strong. Smart. Beautiful.

MATRIX FITNESS | 1600 LANDMARK DRIVE COTTAGE GROVE WI 53527 USA
Toll Free 866.693.4863 matrixfitness.com Fax 608.839.8687

PART # 0000090162

REV. 1.1